

ACOUSTIEG
COMPANY
PROFILE **2026**

V.1.6

Table of **CONTENTS**

About ACOUSTIEG	02
Our Mission	03
Our Vision	03
Why Choose ACOUSTIEG?	04
Our Core Services	05
· Consulting Services	05
· Acoustic Services	06
Industries We Serve	08
Technical Capabilities	09
· 1. Design Software	09
· 2. Measurement Equipment	09
Our Team	10
Our Partners	15
ACOUSTIEG Projects	16
ACOUSTIEG Health & Safety	39
Acoustic Products	41

About **ACOUSTIEG**

Founded in 2018, **ACOUSTIEG** is one of Saudi Arabia's pioneering companies specializing in acoustic treatment and sound isolation. We offer innovative solutions tailored to various industries, delivering exceptional sound environments that enhance comfort, privacy, and functionality.

Our expertise spans consulting, design, installation, and turnkey project management, making us a trusted partner for clients seeking optimal sound performance and noise control.

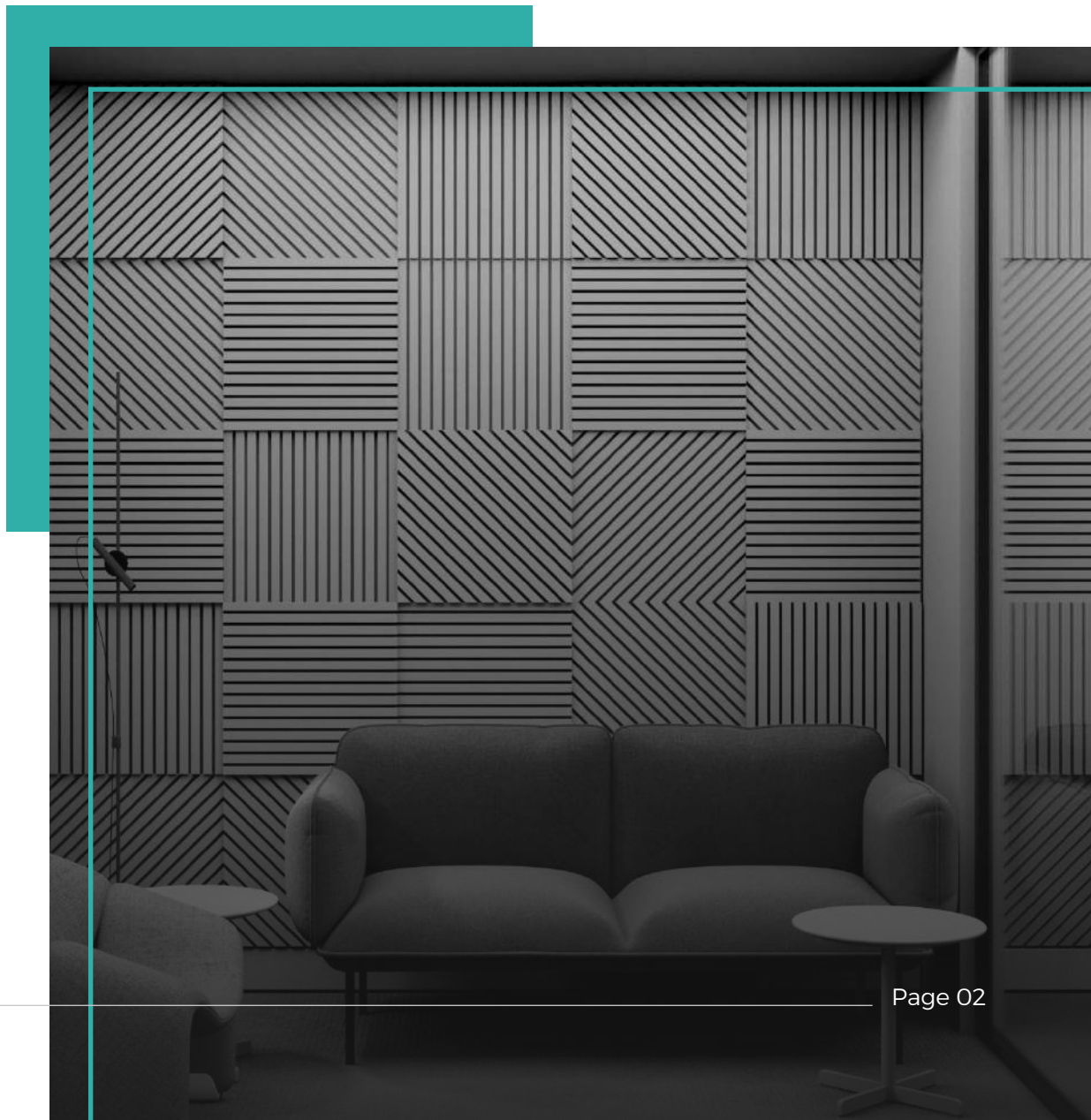



Success
seems to be
connected
with action.



Mission Statement

To deliver **cutting-edge acoustic solutions** that improve sound environments, enhance privacy, and promote well-being in all spaces **where sound matters**.



Vision Statement

To be the leading provider of **innovative acoustic solutions** in **the Middle East**, recognized for our commitment to excellence, technological expertise, and dedication to creating exceptional soundscapes.

Why Choose **ACOUSTIEG?**

Specialized Expertise

Our experienced engineers and consultants are experts in sound physics, vibration analysis, and noise control, equipped to **handle complex acoustic** challenges.

Tailored Solutions

We provide customized solutions that meet the **specific needs** of each project, from small offices to large industrial facilities.

Comprehensive Services

From consulting and design to full implementation, we offer **end-to-end** acoustic solutions.

Advanced Technology

Using the latest design software and measurement tools, we ensure precise results and **optimal sound performance**.

Our **CORE SERVICES**



Consulting Services

We provide expert consulting services to help clients achieve optimal sound environments:

01

1. NOISE SURVEY

Detailed on-site assessments to measure noise levels and identify specific sound-related issues, with tailored recommendations for effective noise control.

2. ACOUSTIC CONSULTANCY

Specialized advice and planning to optimize acoustic performance in various environments, including offices, theaters, and industrial spaces.

3. ACOUSTIC DESIGN SERVICES

Customized design strategies focused on improving sound clarity, reducing unwanted noise, and optimizing acoustics for both comfort and functionality in different settings.

4. SOUND PROOFING CONSULTANCY

Bespoke solutions to reduce sound transmission, enhance privacy, and create quieter, more peaceful spaces in residential, commercial, and industrial buildings.

5. NOISE REDUCTION CONSULTANCY

Practical strategies and recommendations to control excessive noise and improve the acoustic environment, boosting comfort, productivity, and well-being.

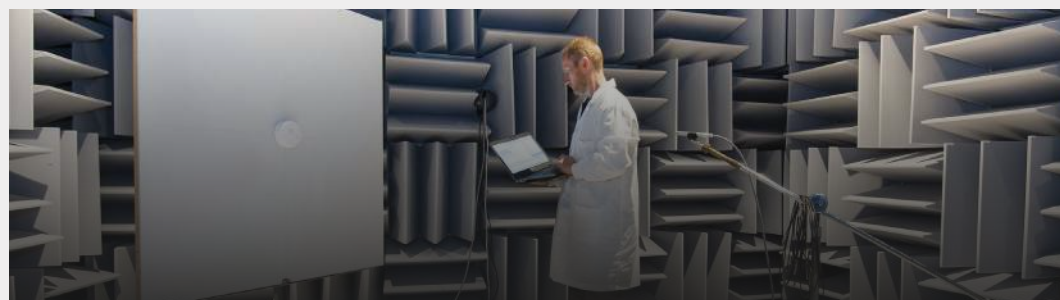

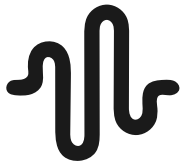

Acoustic Services

Acoustieg offers a range of specialized services tailored to diverse acoustic needs:

02

1. ACOUSTIC SPRAY

Seamless application of sound-absorbing spray for large, open spaces, reducing echo and improving overall acoustic comfort.



2. FABRIC STRETCH SYSTEM

Custom fabric installations that enhance room acoustics by controlling sound reflections and improving clarity in spaces like offices or auditoriums.



3. SOUND MASKING SYSTEM

Systematic sound masking to enhance speech privacy and reduce distractions, ideal for open-plan offices and healthcare facilities.

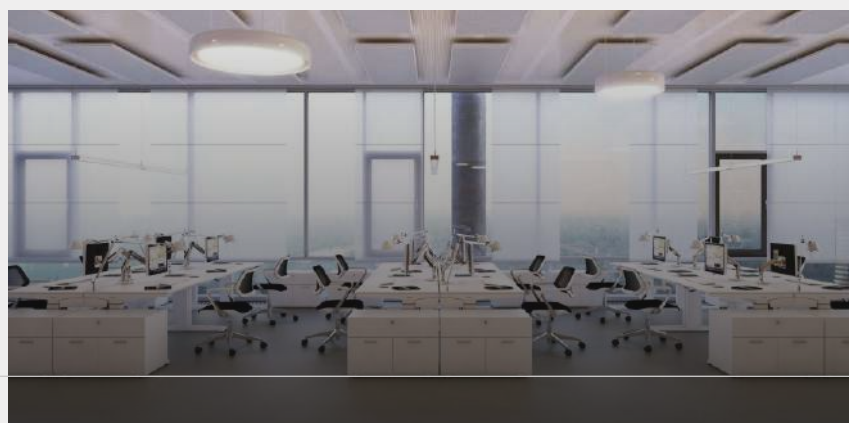

4. BOX IN A BOX SYSTEM

High-performance isolation systems for sensitive environments, such as recording studios or home theaters, preventing sound leakage and vibration.

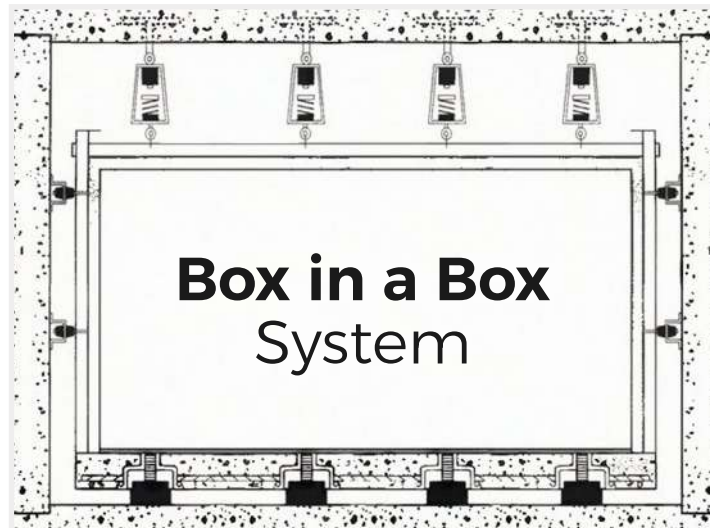

5. FLOATING FLOOR, CEILING, AND WALL SYSTEMS

Advanced systems designed to minimize sound transmission between rooms, improving privacy and comfort in residential and commercial buildings.

6. TURNKEY SOLUTIONS

Comprehensive project management services, from acoustic design and planning to installation and final execution, ensuring a seamless process from start to finish.

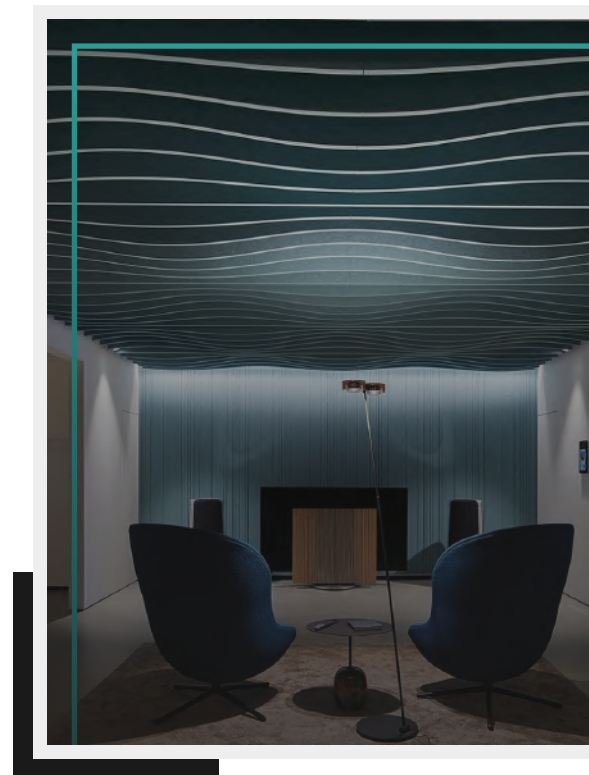

Industries **WE SERVE**

Acoustieg provides customized solutions across various industries:

- ✓ **Entertainment & Media:**
Studios, cinemas, theaters, and radio stations.
- ✓ **Commercial Spaces:**
Offices, conference centers, and coworking spaces.
- ✓ **Public & Cultural Spaces:**
Halls, mosques, stadiums, and sports facilities.
- ✓ **Hospitality & Healthcare:**
Hotels, resorts, hospitals, and healthcare facilities.
- ✓ **Restaurants & Lounges:**
Cafes, restaurants, and entertainment venues.
- ✓ **Transportation & Industrial:**
Airports, factories, and other high-noise environments.

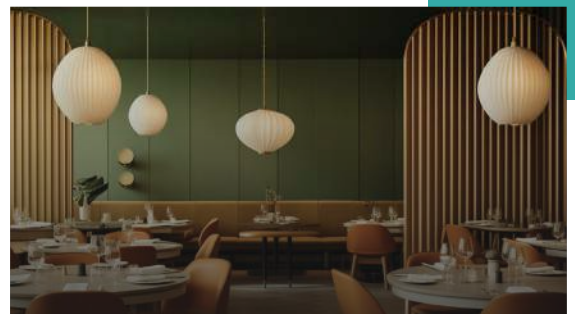

Technical CAPABILITIES

1. DESIGN SOFTWARE

We use advanced design tools to ensure accurate acoustic solutions:

- Odeon Combine
- SketchUp
- ZOBRA
- CadnaA
- Sound Plan
- Insul
- SolidWorks

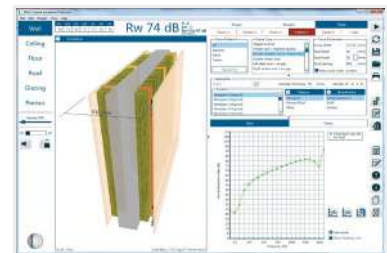
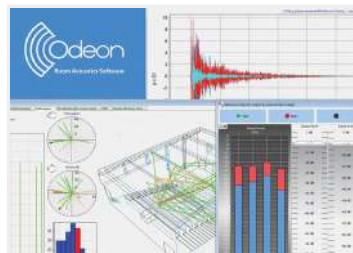
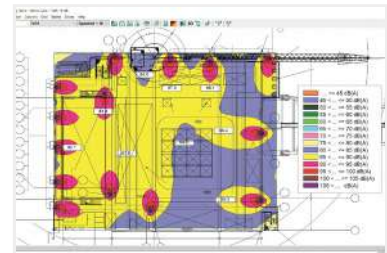
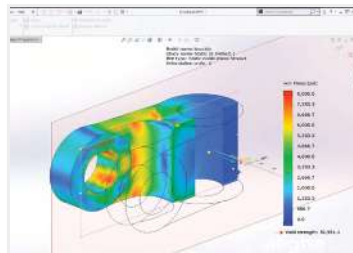

2. MEASUREMENT EQUIPMENT

Our advanced tools ensure precise analysis and effective solutions:

- NTi Audio Devices
- Svantek Meters
- Nor150 Analyzer
- Dodecahedron Speakers



Our TEAM

Our team of experienced acoustic consultants and engineers specialize in:



Sound Physics

Optimizing sound waves for superior acoustic environments.



Noise Control

Developing strategies to minimize unwanted noise.



Vibration Analysis

Reducing the impact of vibrations in sensitive spaces.



Room Acoustics

Enhancing sound clarity and performance through advanced modeling and design.



Eng. Mohammed Al-Hoshan

CEO & Founder

A skilled sound engineer, he holds a Bachelor's degree in Electrical Engineering from KFUPM. With a passion for acoustics and extensive expertise in sound engineering, he has driven Acoustieg to become a leading provider of innovative acoustic solutions in Saudi Arabia.

Dr. Mohammed Al-Rashed

COO

Dr. Mohammed Alrashed has vast experience in business development, operations, and strategic leadership across multiple industries. His innovative approach and commitment to collaboration have established ACOUSTIEG as a trusted leader in acoustic engineering solutions.



Core CONTRIBUTORS

A selection of the skilled professionals driving innovation and excellence at ACOUSTIEG.



Eng. Abdulrahman Al-Wadaei
Head of Commercial

A results-driven commercial leader with a strong track record in revenue growth, market expansion, and strategic partnerships locally and globally, certified in Lean Six Sigma and OSHA, with proven success at Procter & Gamble where he led key initiatives and earned the Gold Award for outstanding performance.



Abdulrahman Al-Zaid
Finance Manager

Dedicated finance professional with a degree in Accounting from the College of Economics and Administrative Sciences, experienced in managing budgeting, reporting, and compliance with precision, providing clear financial oversight while supporting both daily operations and long-term strategic objectives with integrity.



Mohammed Al-Nayli
Commercial Manager

Oversees strategic direction, operations, and growth initiatives, leveraging 15+ years of experience across technical, commercial, and organizational roles in construction and acoustics, recognized for enhancing clarity, efficiency, and team alignment to drive consistent execution and sustainable development.



Eng. Mohammad Qartillu
Head of Engineering

Engineering Expert with over 16 years of experience across Middle Eastern markets, specializing in noise and vibration solutions and complex engineering project management, with strong expertise in sales engineering, technical support, and strategic partnership development to deliver precise, sustainable solutions that meet the highest standards of quality and efficiency.



Eng. Mohammed Odeh
Project Management Office (PMO) Manager

Project Management and Operations Expert with over 22 years of experience in developing workflow systems, enhancing operational efficiency, and leading project execution methodologies to ensure high-quality delivery, stronger team performance, and seamless integration between engineering, creative, and operational functions.



Eng. Mohammed Abu Alrub
Sr. Sales Engineer

A Civil Engineer with 5 years of experience in construction and fit-out works, contributing to residential, commercial, and infrastructure projects. Skilled in site management and technical execution, ensuring quality, safety, and compliance. Detail-oriented and eager to grow, supporting team success with dedication and precision.



Eng. Mohammed Alnaji
Sr. Sales Engineer

A Civil Engineer with over 5 years of experience in sales operations and construction sales, specializing in advanced building technologies. Proven track record in business development, client relationship management, and delivering value-driven solutions for commercial, industrial, and infrastructure projects. Skilled at bridging technical requirements with commercial objectives to support project success and long-term client partnerships.



Dr. Tarek El-Basheer
Acoustics Consultant

Acoustics expert with 12+ years in material, building, and electroacoustics, plus noise assessment. Ph.D. in Experimental Physics with 25+ papers. Led acoustic designs and contributed to global metrology projects. Active in AFRIMET, BIPM, APMP, and GULFMET, combining science with practical expertise.



Eng. Joel Liam Cooke
Acoustic Engineer

Acoustic Engineer with experience in environmental noise and building acoustics. Holds a Diploma in Acoustics and Noise Control awarded by the Institute of Acoustics, and a Master's in Speech Analysis. Experienced in working on both built environment and infrastructure projects across the UK and KSA.



Eng. Khaled Al-Tamimi
HR Manager & Admin

HR & Administrative professional with 8+ years of experience in HR operations, organizational development, and administration. Skilled in talent acquisition, employee relations, and process optimization. Recognized for improving efficiency and aligning HR strategies with business goals to support sustainable growth.



Eng. Islam Mohammed
Procurement Manager

Experienced Supply Chain Manager with 16 years in infrastructure, electromechanical, real estate, and facilities management. Skilled in procurement, supply chain operations, negotiation, and contract management. Holds a Bachelor's in Management Information Systems from Future Academy - Ain Shams University, a Supply Chain Diploma, and CIPS and ISO 9001 certifications.



Eng. Zeyad Al-Saleh
QA/QC Manager

Holds a Master's in Engineering and is a certified PMP with 7+ years of experience in quality management and supervision. Specialized in construction, acoustics, and materials, ensuring compliance with international standards from inspection to final handover.



Eng. Mostafa El-Sayed
Architectural Finishing Lead

Architect specialized in finishes and façade systems, including acoustic insulation, marble, GRC, and aluminum. Experienced in large-scale projects across Saudi Arabia and the MENA region, skilled in site execution, technical supervision, and quality control, with a strong focus on precision and construction quality.



Eng. Abdallah Mohamed
Field Engineering Lead

An Architect with strong on-site presence, combining design expertise with execution and quality control. At ACOUSTIEG, ensures smooth project delivery through clear coordination of design, schedule, and contractor performance. Certified by the Saudi Council of Engineers, known for leadership, precision, and commitment to high standards.



Eng. Khaled Mohamed
Project Execution Lead

A capable Civil Engineer known for precision, coordination, and commitment to quality. Experienced in managing structural and finishing works across complex projects. At ACOUSTIEG, ensures construction integrity, meets deadlines, and delivers results with confidence through clear communication and calm performance under pressure.



Eng. Mohammed Ragab
Project Support Engineer

A versatile Civil Engineer experienced in technical office tasks, site coordination, and construction documentation. At ACOUSTIEG, oversees acoustic scope execution, managing documentation, quantity takeoffs, and design-site coordination. Recognized for accuracy, discipline, and keeping complex projects on track with strong technical rigor.

OUR PARTNERS



ACOUSTIEG PROJECTS

Project: Red Sea Projects

Project Location: The Red Sea



Work Scope:

This project included the supply and installation of acoustic spray, wooden perforated panels, and polyester fiber baffles for RED SEA GLOBAL, aimed at improving acoustics and aesthetics. The acoustic spray was applied to the ceiling for effective sound absorption and noise reduction. Wooden perforated panels were installed to enhance both sound quality and visual appeal, while polyester fiber baffles were strategically placed to further optimize acoustic performance.

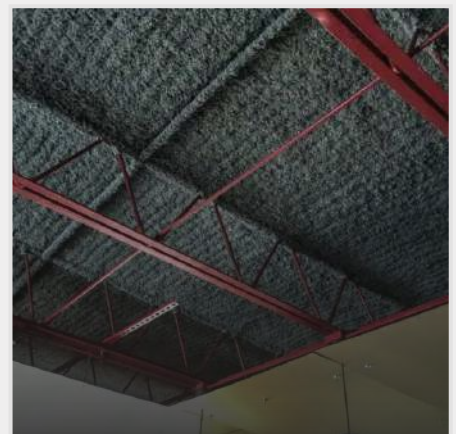
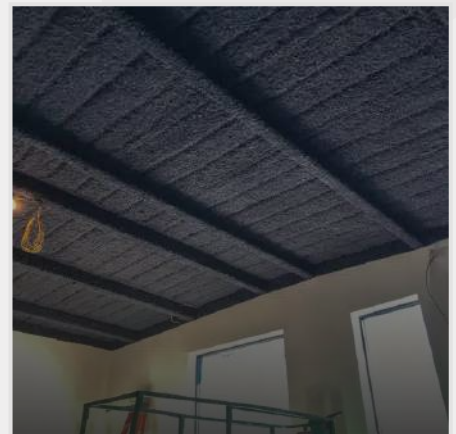
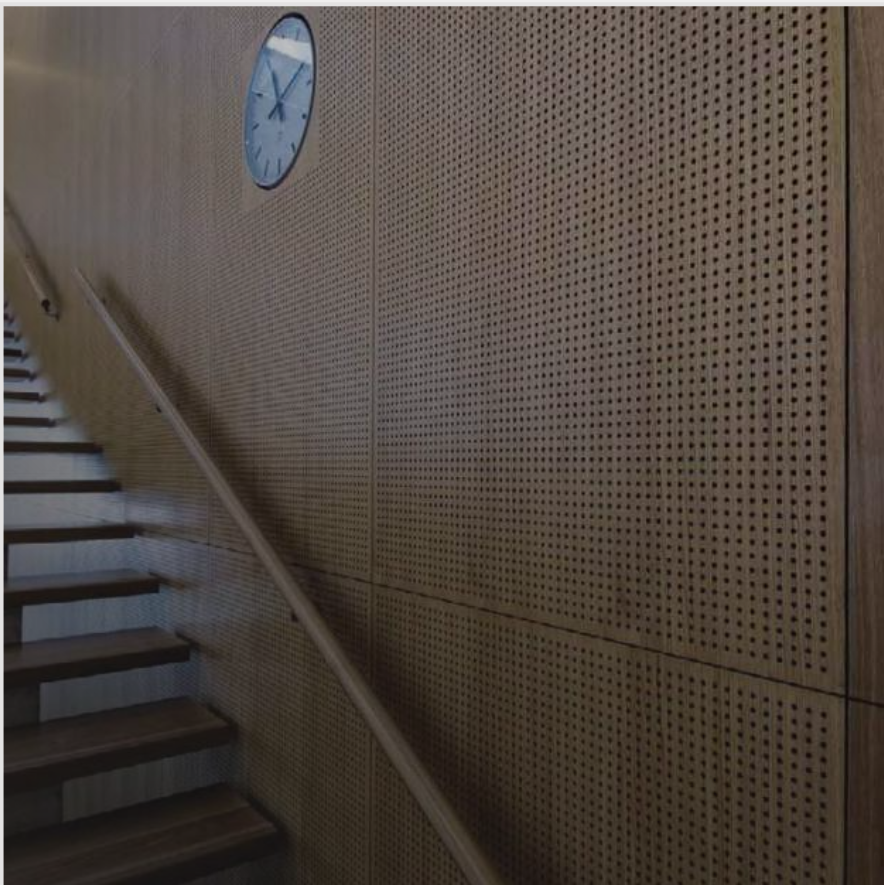



Project: SEVEN

Project Location: Madinah

Work Scope:

SEVEN Project involves supply and installation of acoustic spray to the ceiling for SEVEN, providing an effective solution for noise reduction and sound absorption. The acoustic spray was expertly applied to ensure uniform coverage and optimal performance in controlling reverberation, enhancing overall sound quality. This treatment offered a seamless and aesthetically pleasing finish, tailored to meet the project's specific acoustic needs. The result was a functional, acoustically enhanced, and visually appealing space for SEVEN.

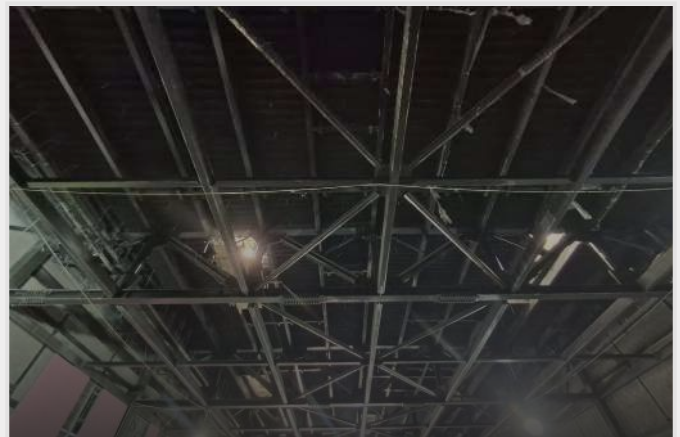
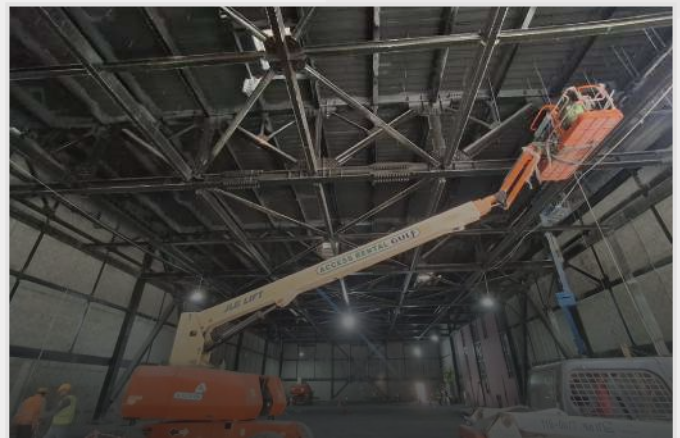

Project: NOKIA Offices
Project Location: Riyadh

NOKIA

Work Scope:

The acoustic treatment for NOKIA Silence Phone Rooms at their head office in Riyadh involved the design and installation of PET acoustic wall panels to enhance sound absorption and privacy. The scope included customized design services to integrate the panels seamlessly with the room interiors while addressing specific acoustic challenges. Acoustic consultancy was provided, covering initial analysis, tailored recommendations, and post-installation testing to ensure optimal performance in controlling noise and reducing reverberation. This project delivered a modern, functional, and acoustically optimized environment in line with NOKIA's standards for workplace quality.

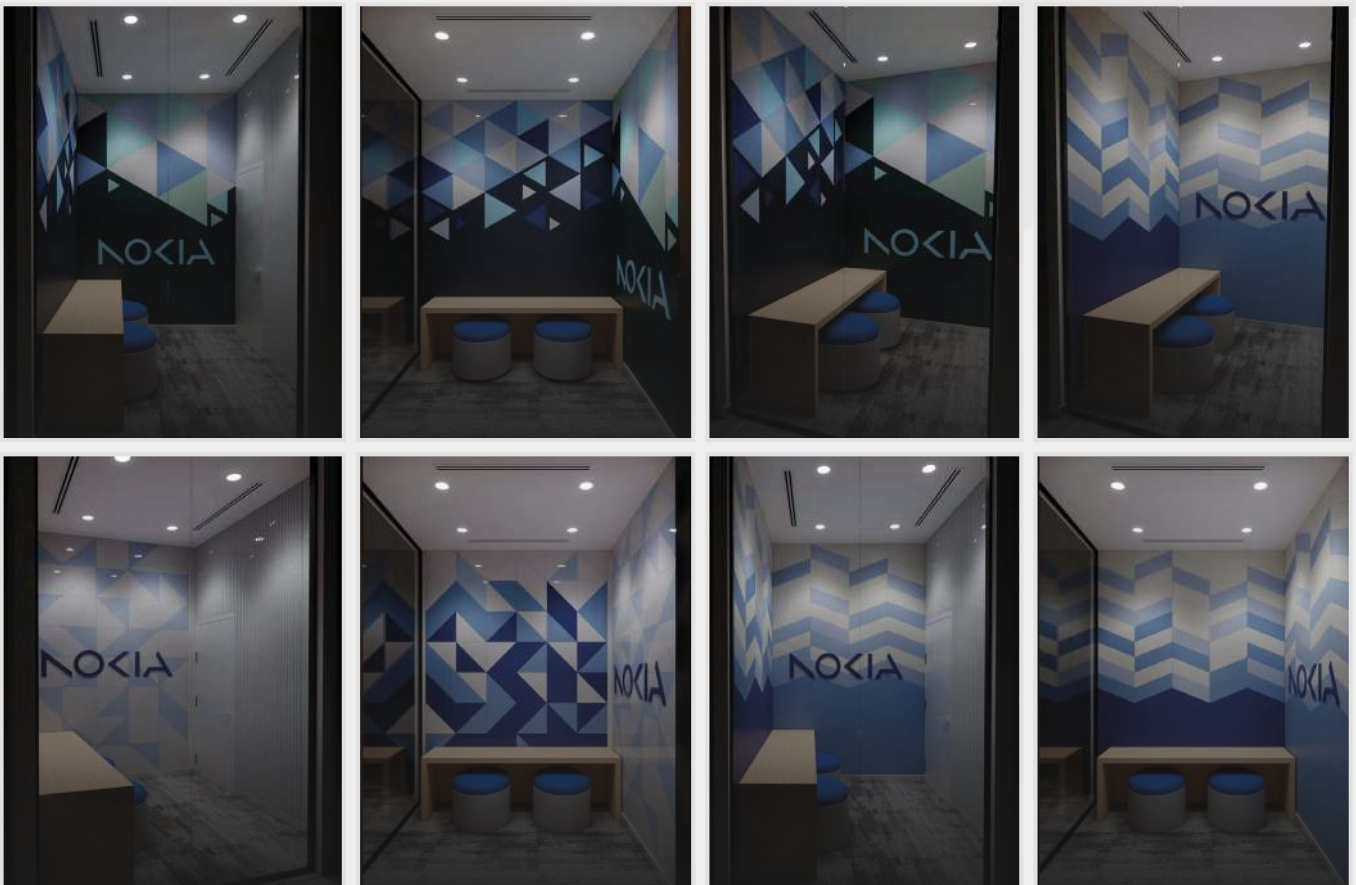

Project: Future Art Studios - Diriyah

Project Location: Diriyah

Work Scope:

The scope of work for acoustic measurement services at Diriyah Company Phase 1 (Future Art Studios) includes assessing reverberation time, background noise, and airborne sound insulation in various rooms, such as lecture halls, studios, and control rooms. The project involves the use of specialized equipment (e.g., sound analyzers, directional loudspeakers) and adheres to international standards like ISO 16283-1 and ISO 3382. Measurements were conducted with detailed procedures to evaluate noise levels, sound insulation, and reverberation characteristics, followed by comprehensive reporting to ensure compliance with specified acoustic performance criteria.



Project: Human Resources Development Fund

Project Location: Jeddah



Work Scope:

The acoustic treatment for the Human Resources Development Fund office's involved the supply and installation of acoustic ceiling baffles to improve sound quality and reduce noise levels in key areas. The scope of work included delivering high-performance baffles designed to enhance sound absorption and control reverberation while maintaining an aesthetically pleasing appearance. Professional installation services ensured precise placement and secure mounting, optimizing acoustic performance and aligning with the organization's functional and design requirements. The project successfully created a balanced and comfortable acoustic environment suitable for the Fund's operational needs.

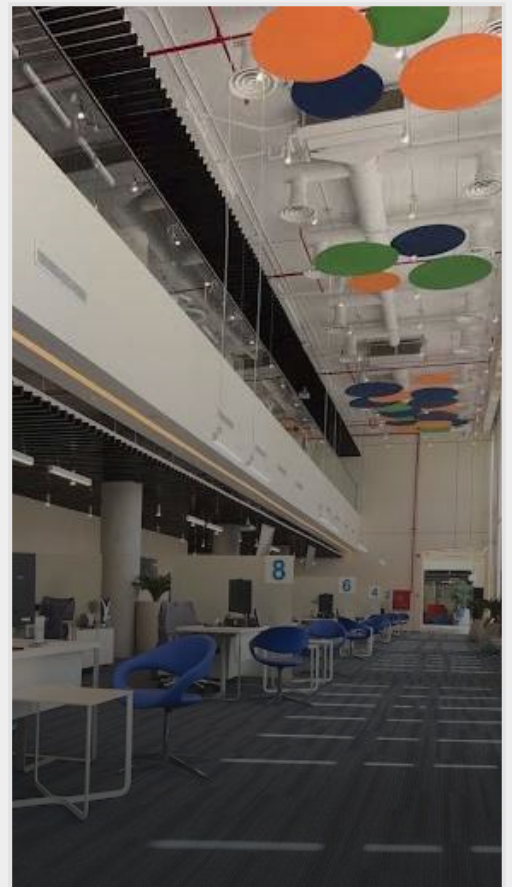
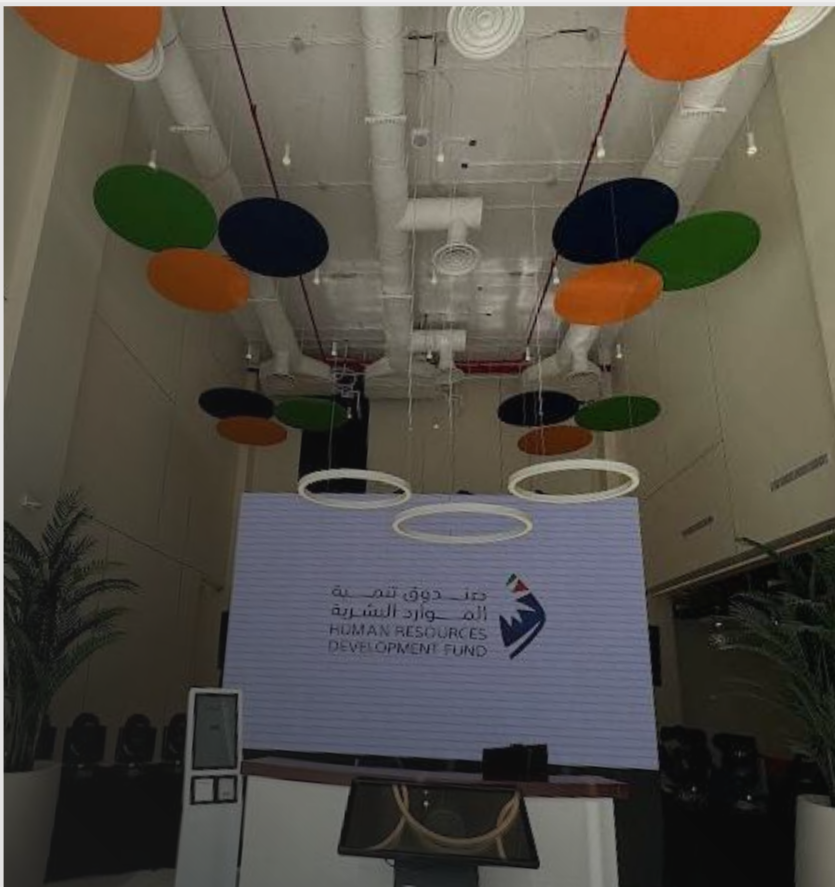

Project: Wave II Schools Project - Ministry Of Education

Project Location: Madinah



Work Scope:

The acoustic treatment for 30 schools involved the supply and installation of wood wool acoustic panels on the walls to enhance sound absorption and create an improved learning environment. The scope of work included providing durable and eco-friendly wood wool panels, tailored to the acoustic needs of each school, and professionally installing them to ensure effective noise reduction and reverberation control. The project delivered acoustically optimized spaces that promote better communication and focus, aligning with the educational objectives of the schools.



Project: BEC Offices

Project Location: Riyadh

BEC العربية
ARABIA

Work Scope:

The acoustic treatment for BEC offices involved the supply and installation of PET acoustic circular baffles on the ceiling to enhance sound absorption and reduce noise levels in the workspace. The scope of work included providing lightweight, durable, and visually appealing PET baffles designed to improve acoustic performance while complementing the office's modern interior design. Professional installation ensured precise alignment and secure suspension, optimizing noise control and reverberation reduction. This project successfully delivered a comfortable and productive acoustic environment tailored to the needs of the BEC office.



Project: Siemens Energy Offices Project

Project Location: Jeddah

Work Scope:

The scope of work involved the supply and application of acoustic spray to the ceiling, providing an efficient solution for noise reduction and sound absorption. The acoustic spray was professionally applied to ensure uniform coverage and optimal performance in controlling reverberation and enhancing overall sound quality. This treatment offered a seamless and aesthetically pleasing finish, tailored to the project's specific acoustic requirements. The result was a functional and visually appealing space with improved acoustic performance.

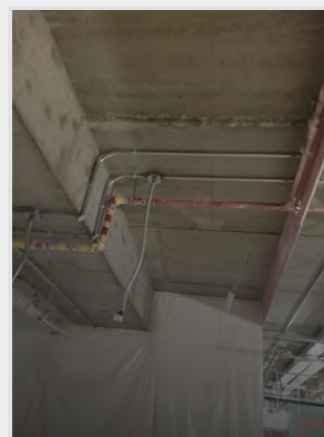
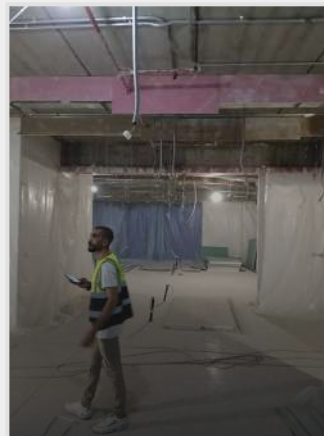

Project: National ELearning Center

Project Location: Riyadh

Work Scope:

The acoustic treatment of a large circular hall involved the use of an Acoustic Fabric Stretch System installed on the walls to enhance sound absorption and control reverberation, ensuring optimal auditory clarity and comfort. The scope of work included comprehensive acoustic consultancy to analyze the hall's unique acoustic challenges and provide tailored solutions. High-quality fabric stretch panels were supplied and professionally installed, ensuring a seamless finish that complemented the hall's design. This project successfully created an acoustically balanced environment suitable for various events and functions.

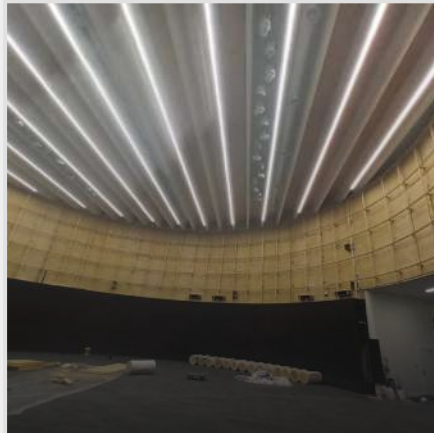



Project: VOZ Studio

Project Location: Riyadh

Work Scope:

VOZ Studio Project involves designing and constructing a sound studio, office lounge, and office spaces. The sound studio will feature optimal sound isolation, high-quality soundproofing, and a quiet HVAC system. The office lounge aims to provide a comfortable area for relaxation and informal meetings, with cohesive furnishings and décor. The office spaces are designed for efficiency, incorporating adequate lighting and ventilation. Throughout the project, we will adhere to local building codes, conduct regular quality inspections, follow a detailed project schedule, and enforce strict on-site safety protocols.

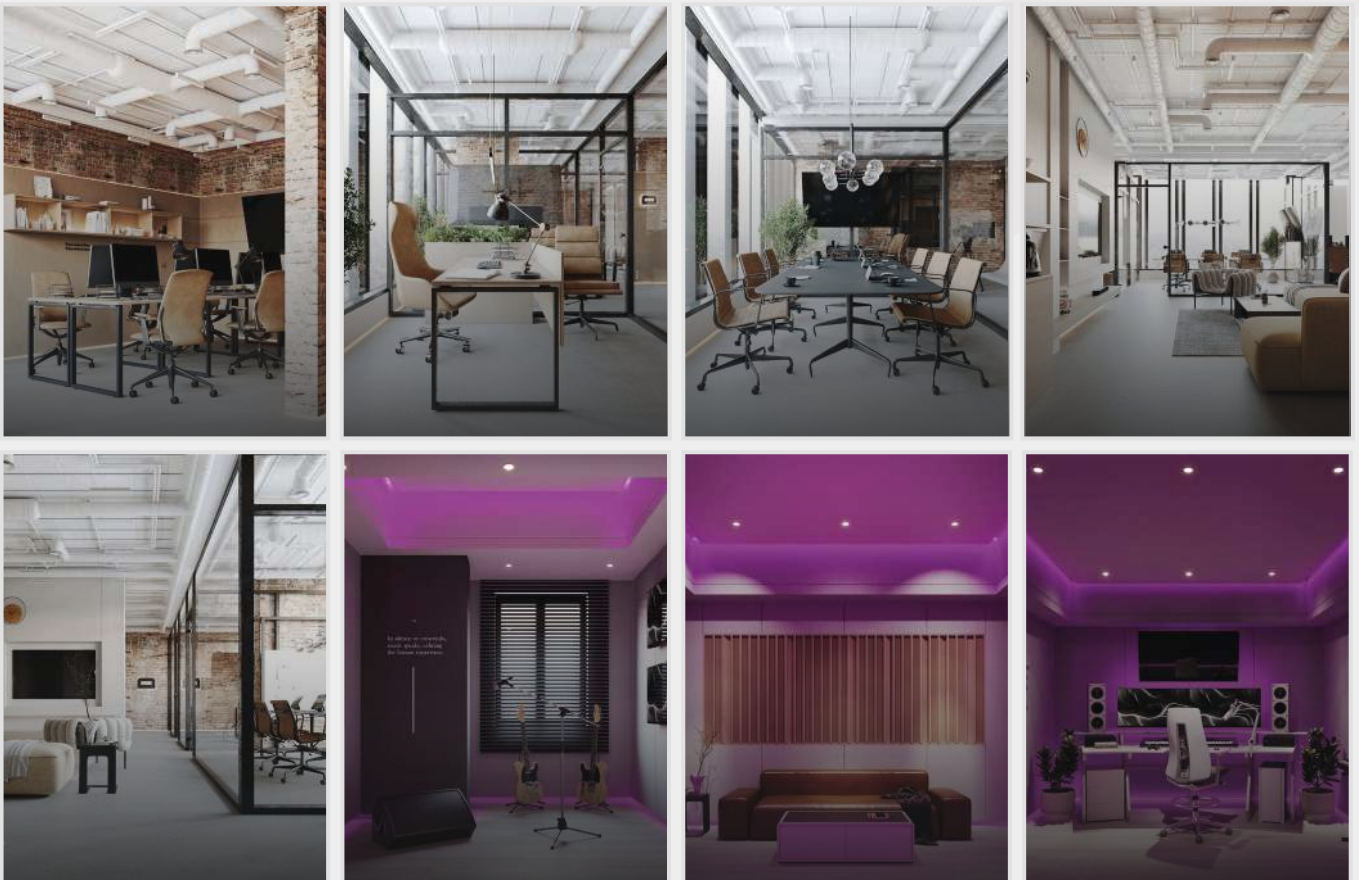

Project: Qiddiya Project - Six Flags

Project Location: Qiddiya



Work Scope:

The acoustic treatment for the Qiddiya 6 Flag Project in Riyadh, for BBIAGCJV Joint Ventures, involves the supply and application of Acoustic Spray (BoSpray) – a high-performance, spray-applied acoustic insulation. The scope includes the professional application of BoSpray, achieving a High Noise Reduction Coefficient, ensuring effective sound absorption and superior noise control. The treatment is designed to deliver optimal acoustic performance across the designated spaces, reducing reverberation and enhancing auditory comfort, while maintaining a seamless and aesthetically pleasing finish aligned with the project’s architectural requirements. This solution provides a durable, high-quality acoustic environment suitable for the diverse functional needs of the Qiddiya 6 Flag Project.





Project: Aramco

Project Location: Al Jubayl

Work Scope:

The acoustic treatment for the ARAMCO Dammam Field in Al Jubayl (Jubail Industrial City) for ARAMCO involves the supply and installation of Acoustic Fabric Panels. The scope includes delivering high-performance fabric acoustic panels designed to enhance sound absorption and control reverberation, creating a balanced and comfortable acoustic environment within the designated spaces. Professional installation ensures precise placement and secure mounting, aligning with ARAMCO's standards for functionality, aesthetics, and durability. The result is an acoustically optimized and visually appealing environment tailored to the project's operational and design requirements.

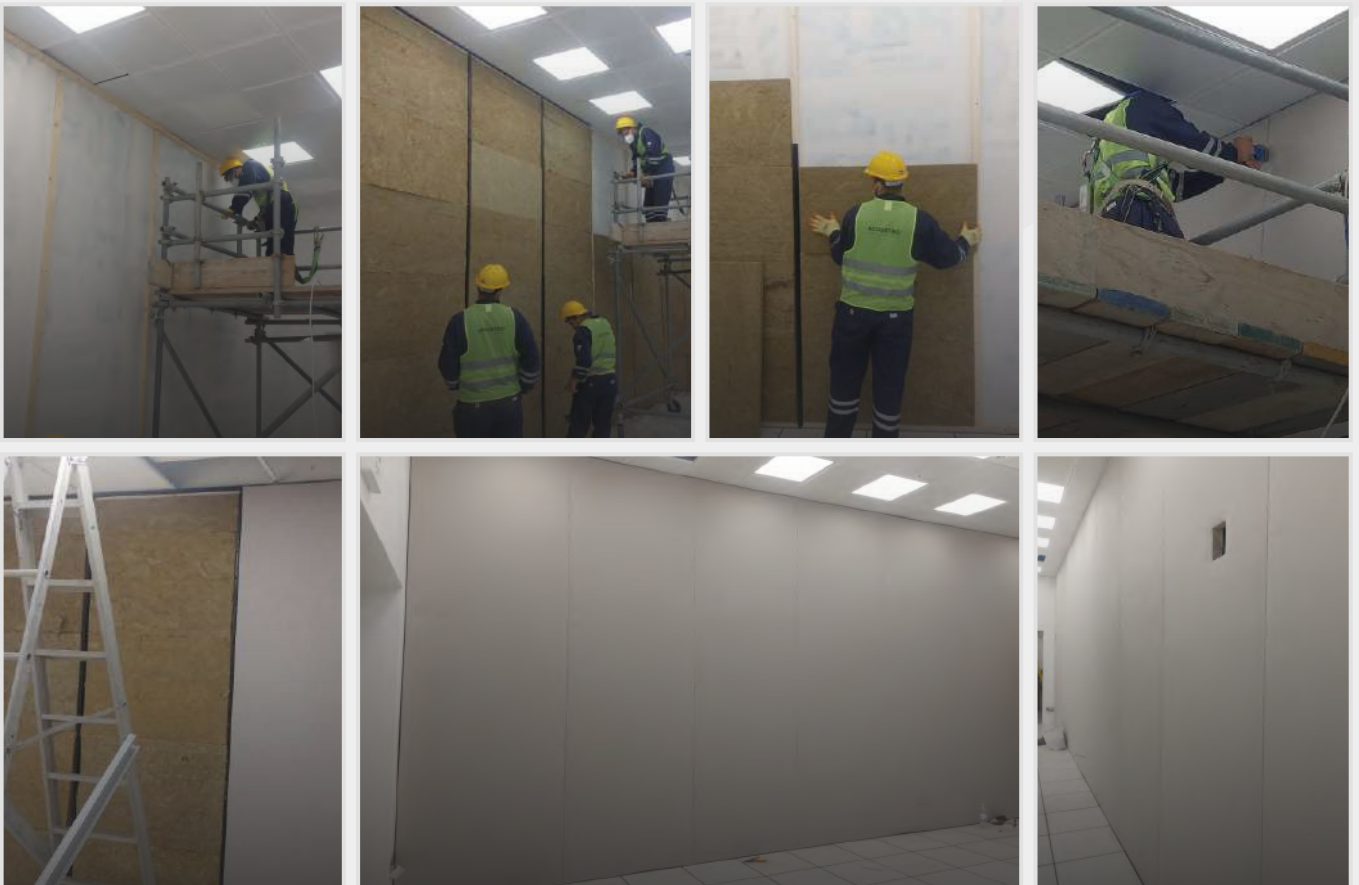

Project: Roshn Front

Project Location: Riyadh

Work Scope:

The acoustic treatment for the Roshn Front Project in Riyadh, for Archi-Site Company, involves the supply and application of Acoustic Spray (BoSpray). The scope includes the professional application of BoSpray, a high-performance, sprayed sound insulation material that effectively reduces noise and echoes. Applied seamlessly to walls, ceilings, and other designated surfaces, this treatment enhances sound quality, controls reverberation, and provides a clean, aesthetic finish. The solution is tailored to the project's acoustic and architectural needs, ensuring optimal performance and visual harmony.

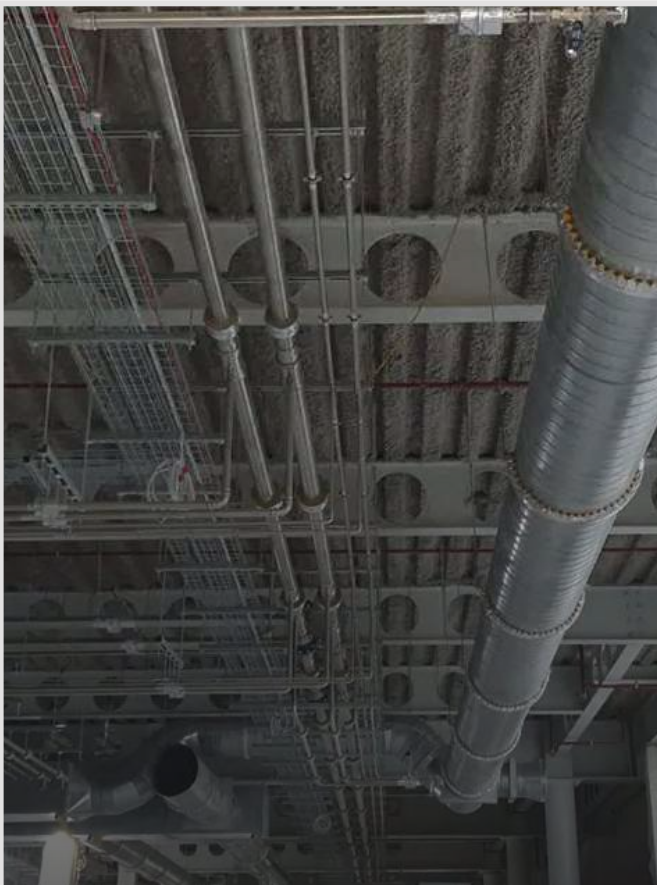

Project: Ministry of Energy
Project Location: Riyadh

وزارة الطاقة
MINISTRY OF ENERGY



Work Scope:

A detailed acoustic study was conducted for the Ministry's main building, including in-depth measurements of sound insulation, reverberation times, and noise levels across different functional spaces. The study provided actionable recommendations to ensure compliance with noise control regulations and to improve the building's overall acoustic performance.

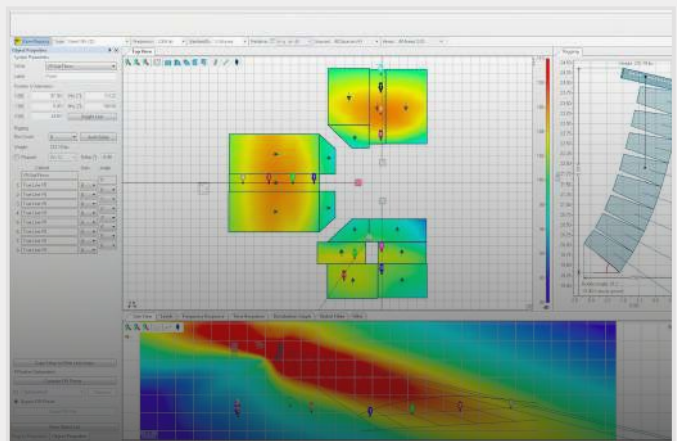

Project: King Fahd University
Project Location: Dhahran



Work Scope:

Comprehensive partition testing was carried out using industry-standard methodologies to evaluate wall and partition sound insulation performance. Results ensured compliance with national and international benchmarks, supporting highquality acoustic design in university learning and research environments.



Project: Siemens Energy Offices

Project Location: Jeddah

Work Scope:

Glass partitions were tested with high-precision analyzers to assess insulation levels and sound leakage. The tests validated compliance with ISO benchmarks for airborne insulation, providing Siemens with technical assurance and solutions for optimizing office privacy.

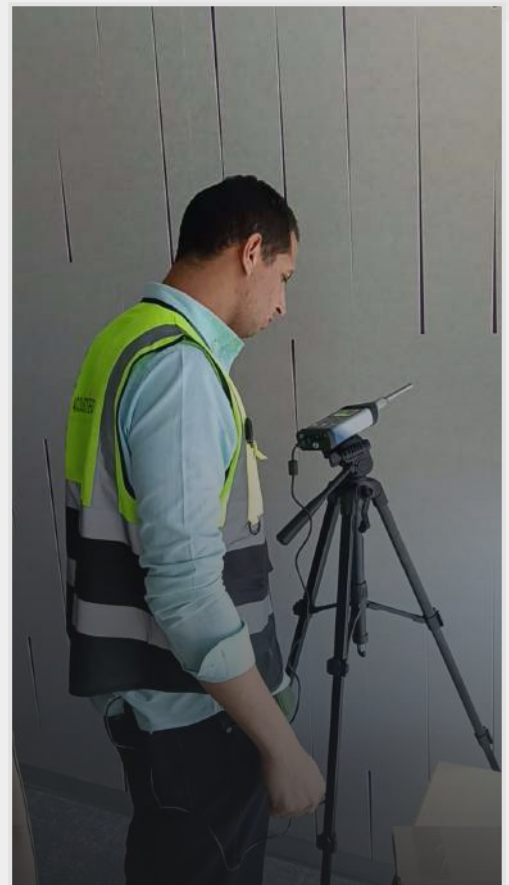

Project: Heratige Comission

Project Location: Riyadh



Work Scope:

Acoustic insulation solutions were integrated into heritage facilities with full respect for cultural and architectural integrity. The systems delivered high-level noise control without compromising the visual or structural authenticity of the heritage sites, achieving a balance between preservation and modern performance.



Project: Turtle Bay School

Project Location: The Red Sea



Work Scope:

Acoustieg delivered a comprehensive acoustic treatment solution for the Turtle Bay School project at The Red Sea, utilizing premium acoustic spray technology to optimize indoor sound quality and acoustic comfort. The solution was engineered to control reverberation, absorb excess noise, and enhance speech intelligibility across educational and communal spaces. Applied seamlessly to exposed ceilings and designated surfaces, the acoustic spray system provides an aesthetically pleasing finish while meeting the project's functional acoustic requirements. This tailored treatment supports a productive learning environment by improving acoustic performance, reducing distractions, and integrating harmoniously with the architectural vision of one of The Red Sea's landmark educational developments.



Project: National Water Company

Project Location: Hail



شركة المياه الوطنية
National Water Company

Work Scope:

Hail Tank Acoustic Treatment project (planned) will feature Metal Perforated Panels and a Floating Floor system. Together, they will reduce industrial noise and improve safety by minimizing structural vibrations.

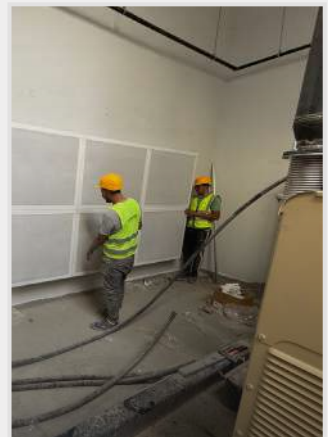
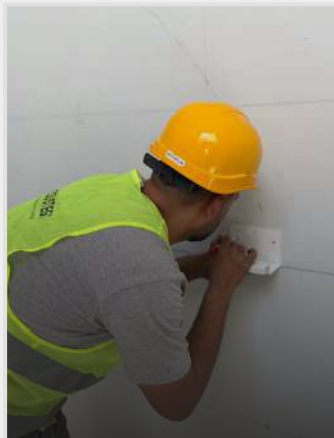

Project: New Murabba
Project Location: Riyadh



NEW MURABBA

Work Scope:

BoSpray Acoustic Spray was applied across large interior spaces to achieve optimal noise control. The seamless finish offered both superior acoustic absorption and architectural elegance, ensuring comfort and performance for diverse public and commercial functions.



Project: ISG Schools

Project Location: Al Jubail



Work Scope:

Classrooms and halls were fitted with a hybrid acoustic solution combining fabric panels and Haylcon ceiling panels. The dual system provided advanced reverberation control, enhanced speech clarity, and compliance with educational acoustic standards, creating an optimal learning environment.

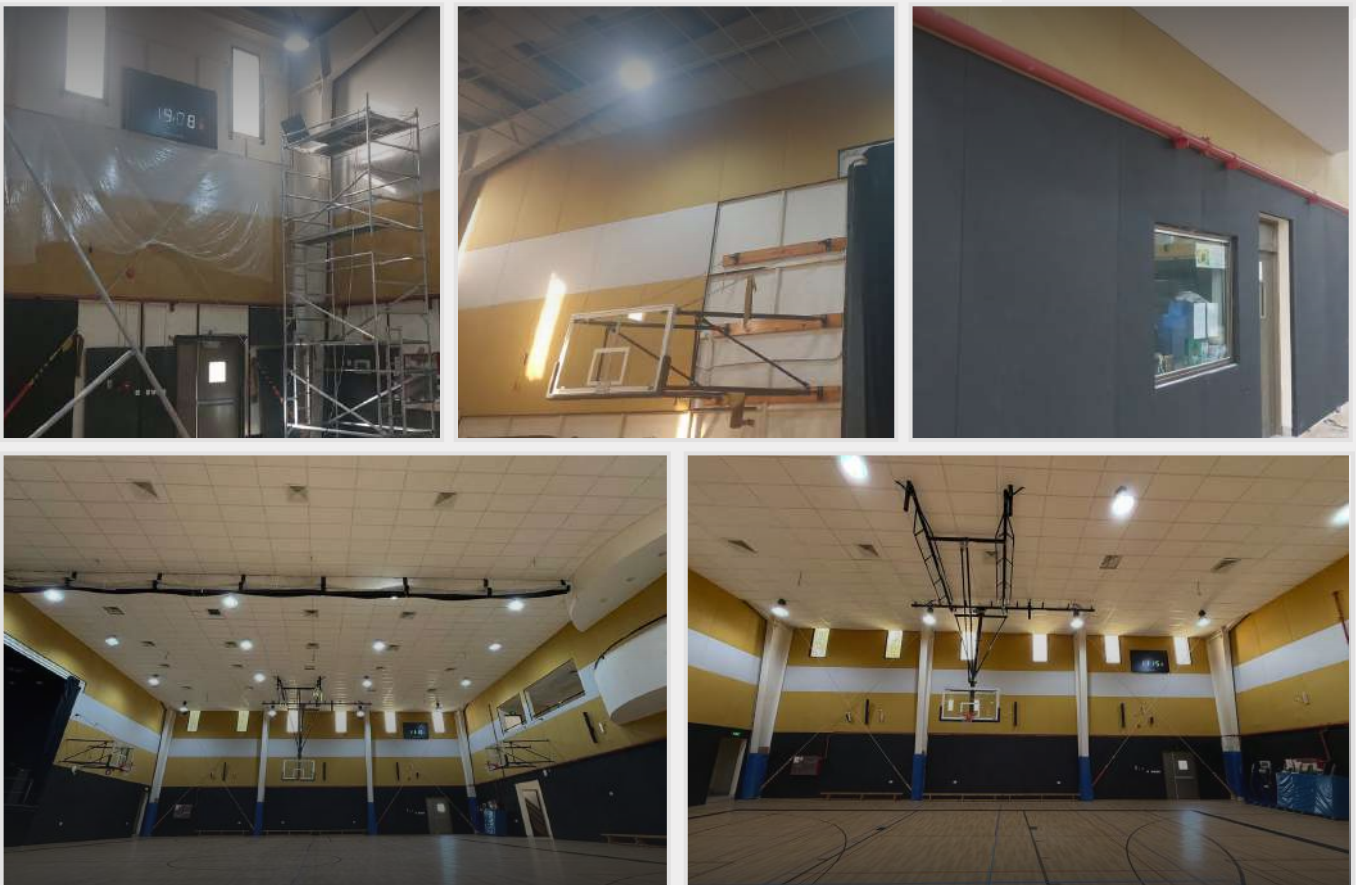

Project: Omni Club

Project Location: Riyadh



Work Scope:

A specialized Box-in-Box system was engineered to isolate structure-borne vibration and ensure maximum soundproofing for the entertainment club. The system provided premium acoustic separation, delivering a high-quality entertainment experience.

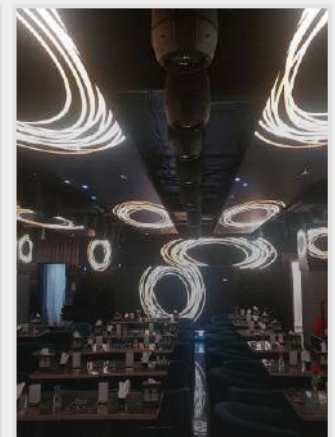
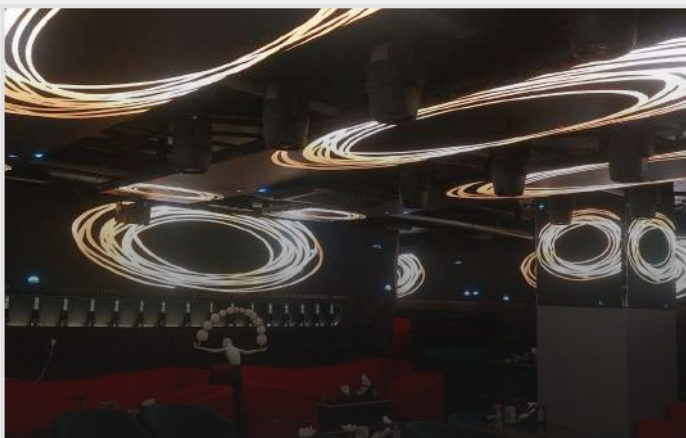

Project: Riyadh University of Arts

Project Location: Irqah, Riyadh



Work Scope:

Provision of comprehensive acoustic engineering services, including acoustic design review and verification, site supervision, testing, and commissioning. The scope encompasses the review and verification of acoustic design criteria, assessment of compliance with applicable standards and performance requirements, and the development of technical recommendations to support the effective implementation of the acoustic strategy. Services also include site supervision activities to monitor acoustic installations, verify compliance with approved specifications, and address technical challenges associated with the project. In addition, testing and commissioning procedures are performed to evaluate acoustic performance and validate the intended design objectives. The overall acoustic approach is aimed at achieving a high-quality acoustic environment that enhances user comfort, supports educational and creative activities, and aligns with the architectural and functional vision of the university.



ACOUSTIEG HEALTH & SAFETY

At ACOUSTIEG, safety is not just a legal obligation—it is a core value embedded into every layer of our operations. As a specialized acoustic contractor working across diverse environments, we prioritize the protection of our team members, clients, and project stakeholders through rigorous safety standards and procedures.



OUR SAFETY FRAMEWORK

1. Strict Safety Policies

- We maintain a robust Health & Safety Management System aligned with ISO 45001 and OSHA standards. These protocols are reviewed and updated regularly to adapt to project-specific risks and evolving industry regulations.

2. Comprehensive Risk Assessments

- Before the commencement of any project, a thorough risk assessment is conducted to identify potential hazards—especially related to sprayable materials, elevated installations, electrical work, and confined spaces.
- All site activities comply with Saudi Civil Defense and local municipal safety requirements.

3. On-Site Safety Protocols

- Mandatory use of Personal Protective Equipment (PPE) including helmets, gloves, goggles, and respiratory masks.
- Secure scaffolding and elevated work platforms used in accordance with engineering and safety guidelines.
- Supervised cutting, drilling, and installation under approved safety plans.

4. Ongoing Team Training

- First aid and fire safety.
- Emergency response procedures.
- Material handling and safe installation practices.
- Weekly toolbox meetings and project-specific briefings.

5. Safe Materials & Certified Systems

- All materials used in ACOUSTIEG projects are:
 - Fire-rated and compliant with ASTM/BS standards.
 - Low-VOC and E1 certified for indoor air safety.
 - Supplied with full Material Safety Data Sheets (MSDS).

6. Monitoring & Incident Reporting

- Active safety logs and incident tracking.
- Routine inspections by internal and third-party auditors.
- Weekly safety performance reports delivered to management.

7. Leadership-Driven Safety Culture

- Our executive team actively oversees the safety strategy and implementation, embedding safety KPIs into project performance and daily operations.



WHAT SETS ACOUSTIEG APART IN SAFETY

- ISO 14001 Certified for Environmental Safety Management.
- Zero major incidents across high-profile projects (Red Sea Global, Siemens Energy, Diriyah, NOKIA).
- Project-specific safety enforcement—e.g., “Strict on-site safety protocols” mandated in Chord Studio.
- Strong partnerships with fireproof and eco-certified material suppliers.



Acoustic **PRODUCTS**

Our product range is designed **to cater to various** acoustic needs across industries:

- Acoustic **PET Panels**
- Acoustic **Wooden Panels**
- Acoustic **Wood Wool Panels**
- Acoustic **Fabric Panels**
- Acoustic **Aluminum Panels**
- Acoustic **Metal Panels**
- Acoustic **Foam**
- Acoustic **Baffles**
- Acoustic **Pods**
- Acoustic **Doors & Windows**
- Acoustic **Underlay**
- Acoustic **Louvers**
- Acoustic **Tiles**
- Acoustic **Barriers**
- Acoustic **Carpet**
- **MLV (Mass Loaded Vinyl)**

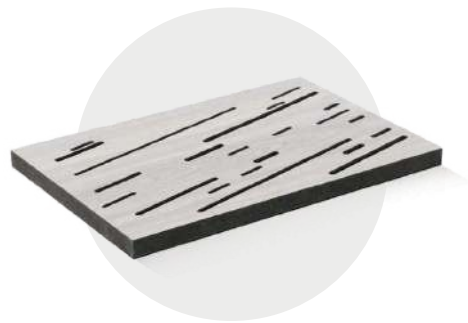

WOODWORKS GRILLE



Product Name:

- Solid Wood liner Ceiling (America)
- Solid Wood Grill (Europe)
- Wood Slat Ceiling (Spain)
- Wooden Acoustic Hanging Baffles (Columbia)

SPECIFICATIONS

Name	Ceiling Woodworks Grillers / Baffles
Structure	Solid wood strips combined (basic solid wood is shiraki, other solid wood is okay)
Finished	Wooden color or painting
Model	See following or drawing
Size(W*L*H)	600*1200*35mm or customized

PERFORATED ALUMINUM CEILING BAFFLE



Application:

Industrial and civil buildings;
Interior decorative panel, partition panel;
Airport, bus station, museum, opera house;
Exhibition hall, shopping centre;
Conference hall, office, bar and etc.

SPECIFICATIONS

Name	Perforated Aluminum Ceiling Baffle
Shape	Square
Finished	Powder coating, spray painting
Color	White, grey, RAL color, etc
Thickness	0.6-2.0mm
Size(W*L*H)	30x3000x200mm or customized
Patterns	Round 2mm stagger perforated or customized
Edge	Square with end-cap
Function	Fireproof board ceiling, soundproof ceiling, integrated ceiling, heat insulation ceiling, moisture-proof ceiling, mould-proof ceiling, waterproof ceiling.

CEILING INSTALL SYSTEM

Accessories

Commercial Ceiling Tiles was derived from germany with advanced & unique production technology, which is the superior product of ACO with professional mold design, even panel surface, distinct edges & lines, and clear & concise.

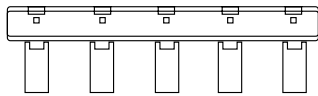

Screw hanging installation method

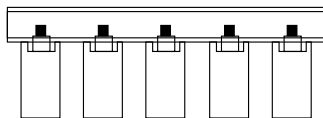
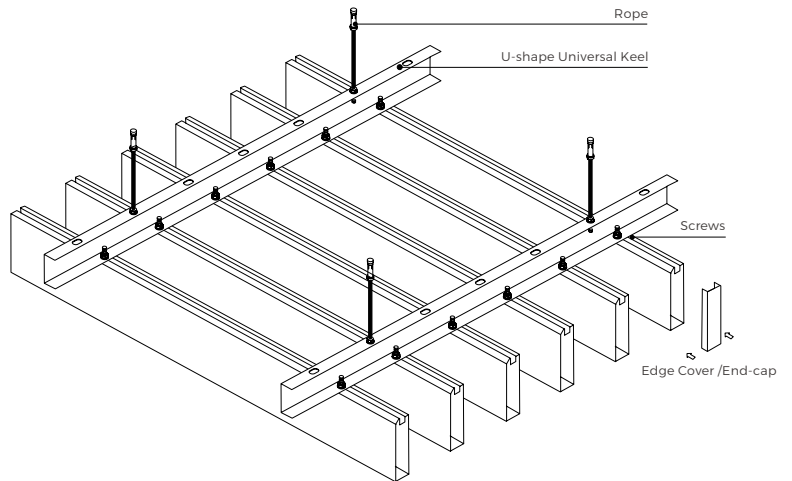
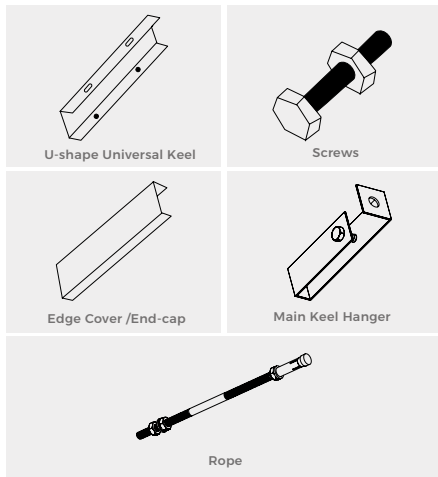

Keel hanging buckle installation method

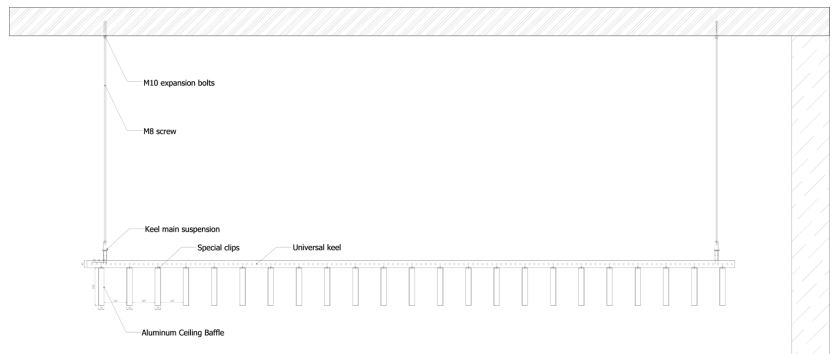
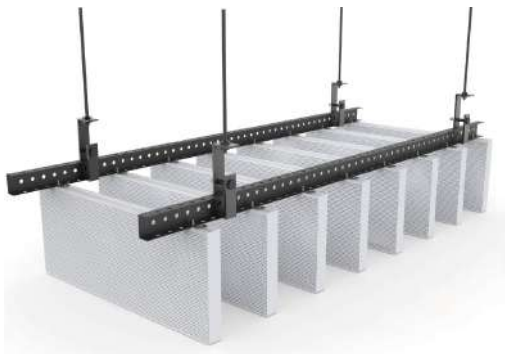

FIBERGLASS CEILING PANEL

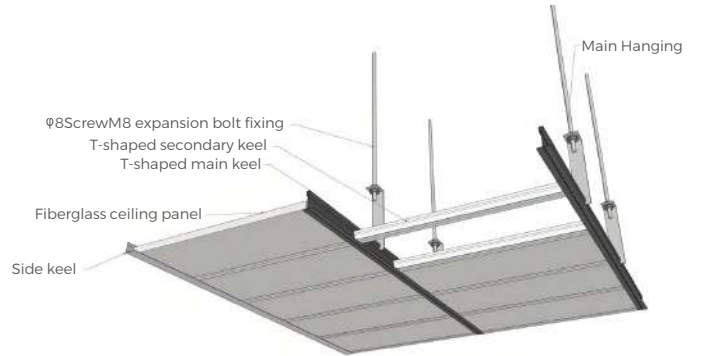
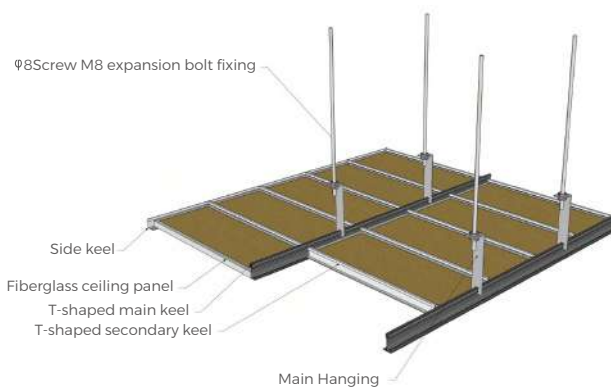
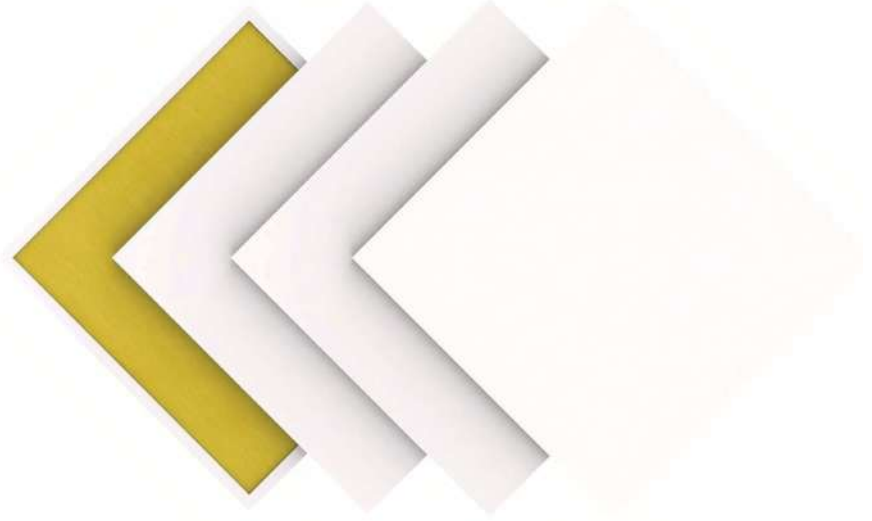

SPECIFICATIONS

Name	Fiberglass Ceiling Panel
Basic Materials	Torrefaction compound high density fiberglass wool
Finished	Painted, spray, dots
Color	15mm, 20mm, 25mm for flat fiberglass panel 30mm, 40mm, 50mm or customized for 3D fiberglass panel
Size(W*L*H)	595*595mm 600*600mm 600*1200mm or customized
Patterns	Square Tegular, Insert, 3D model

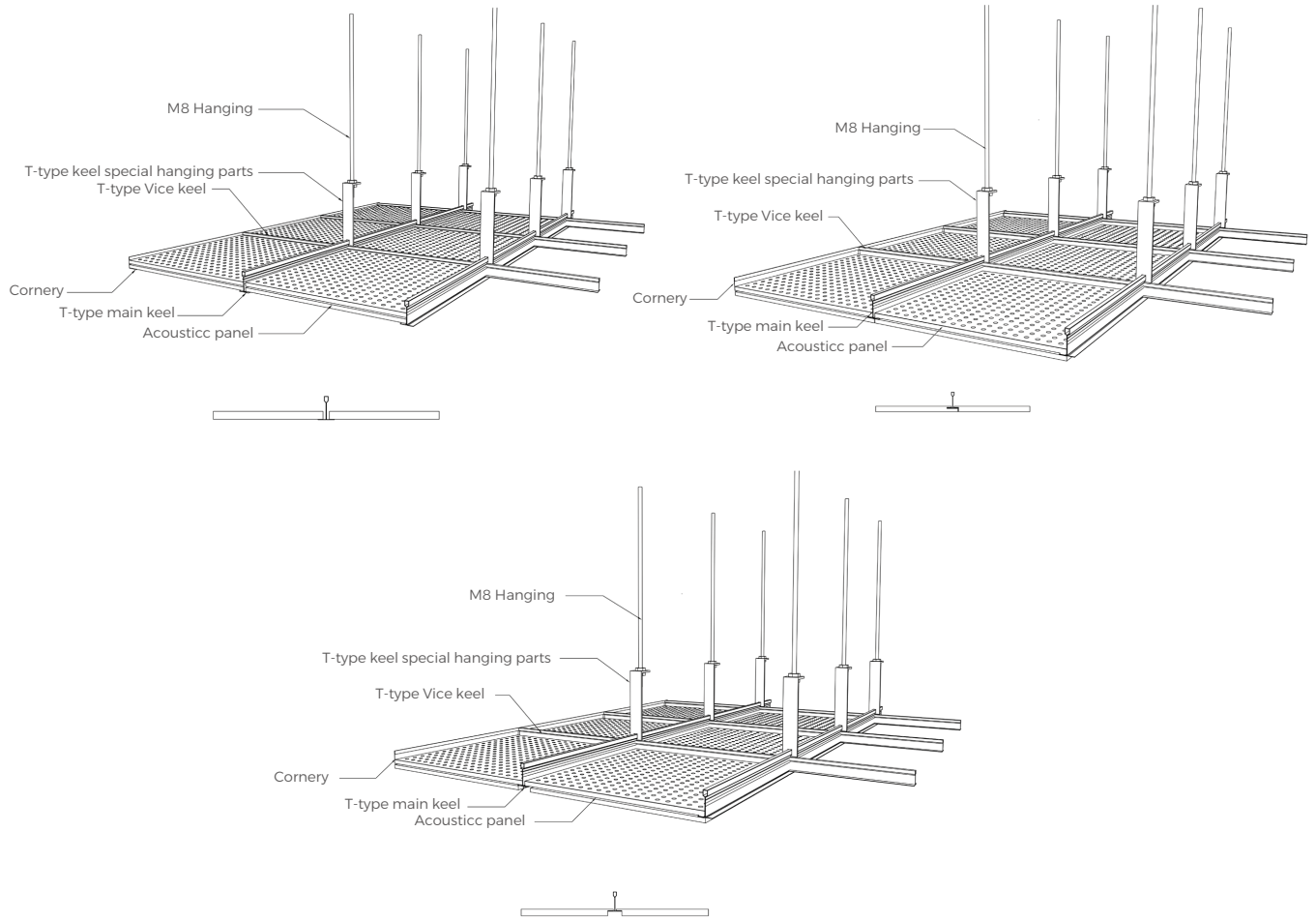

SLATTED WALL ACOUSTIC PANEL



Application:

Commercial premises and offices
Schools and educational buildings
Call centers and reception areas
Theatres
Auditoriums
Conference Centers
Sports Centers
Recording Studios
Cinemas
High traffic public areas

SPECIFICATIONS

Name	Slatted Wall Acoustic Panel
Shape	Square or customized
Finished	Melamine / veneer / HPL
Thickness	21mm / 24mm / 27mm
Size(W*L*H)	600*2400 600*2700mm or customized
Patterns	9mm polyester + MDF strips
Standard	E1 standard

GROOVED WOODEN ACOUSTIC PANEL GA SERIES



PRODUCT INTRODUCTION

Groove acoustic panel is the common sound absorption materials in modern buildings. The structure of groove in surface and perforation in back is based on scientific calculation and acoustic theories. The panel has excellent noise reduction and sound absorption performance, especially for medium and low frequencies. Meanwhile, the natural wood grain and diverse finish choice provide good visual effects for everyone.

SPECIFICATIONS

Name	Grooved Wooden Acoustic Panel GA SERIES
Structure	Base Materials / Finish / Back
Base Materials	Standard / Eco-friendly / Fire-resistant / Moisture-proof / A Grade Non Inflammable / Composite Fire-resistant / Non-formaldehyde Solid Wood / Other customized
Finish	Veneer/Melamine/HPL Fire-proof/PU Painting
Back	Black Fire-resistant Sound Absorbing Fleece/Soundtex Sound Absorbing Fleece
Model	GA59-5 / 40-3 / 28-4 / 18-3 / 14-2 / 13-3 / 9-2 / 5-3 / Other customized models
Common size	W 133mm * L 2440mm * T 15/18/12mm

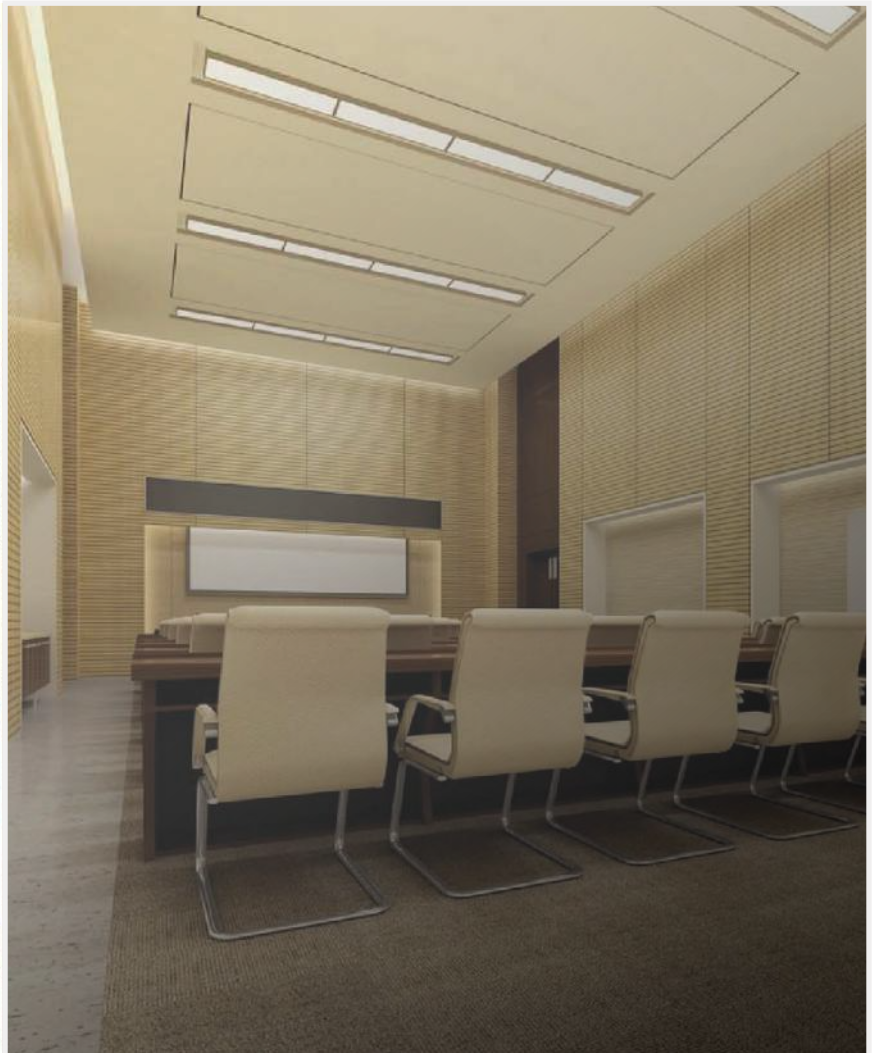
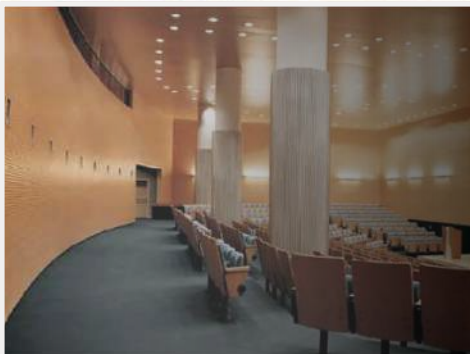
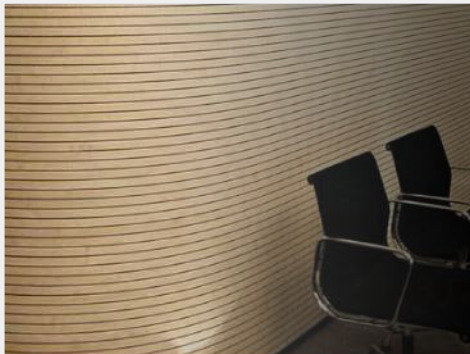

FEATURES

- **Eco-friendly:**

All materials meet the national and international environmental protection standard. The product contains little formaldehyde with natural wood fragrant. Non-formaldehyde is also available.

- **Fire-resistant:**

Fire-resistant panels can reach class A under ASTM-E84 standard, Class 1 under BS476 part 7 standard.

- **Easy Install:**

Standard module product, could be installed easily with keel and fastener.

APPLICATION

Multifunctional Hall, Conference Room, Opera Hall, cinema, Auditorium. Hotel. Tv Station, Music Hall, Piano Room. Gymnasium, Village, Or Any place which has high acoustic request.

59-5



Punching rate 5.5%

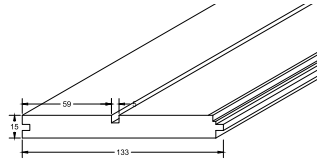

Sound absorption coefficient

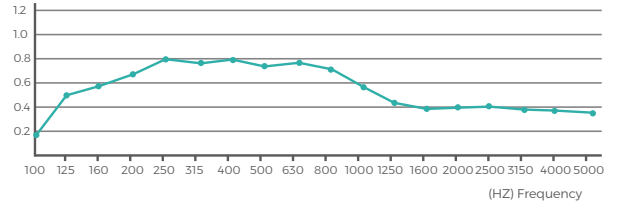

Frequency	100	125	160	200	250	315	400	500	630	800	1000	1250	1600	2000	2500	3150	4000	5000
Sound absorption coefficient	0.15	0.42	0.50	0.60	0.75	0.70	0.78	0.66	0.70	0.62	0.50	0.38	0.35	0.35	0.32	0.32	0.30	0.30

40-3



Punching rate 5.0%

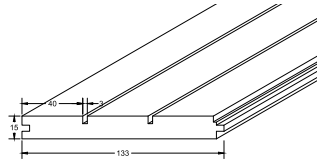

Sound absorption coefficient

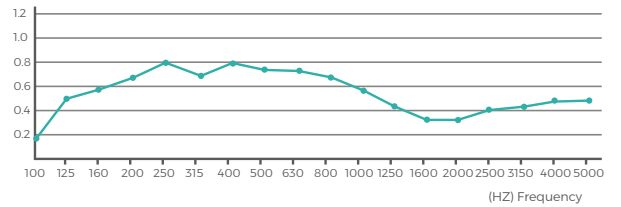

Frequency	100	125	160	200	250	315	400	500	630	800	1000	1250	1600	2000	2500	3150	4000	5000
Sound absorption coefficient	0.20	0.45	0.60	0.70	0.80	0.75	0.82	0.76	0.75	0.62	0.52	0.40	0.37	0.35	0.40	0.40	0.44	0.45

28-4



Punching rate 8.0%

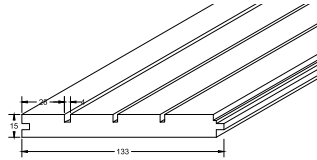

Sound absorption coefficient

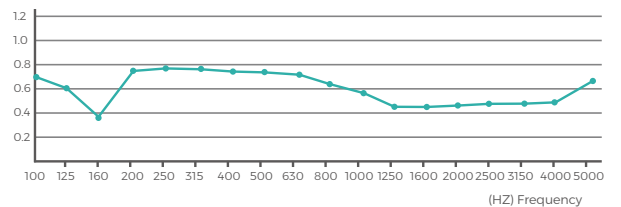

Frequency	100	125	160	200	250	315	400	500	630	800	1000	1250	1600	2000	2500	3150	4000	5000
Sound absorption coefficient	0.69	0.60	0.40	0.98	0.96	0.86	0.92	0.86	0.87	0.72	0.62	0.48	0.47	0.45	0.50	0.50	0.54	0.70

18-3

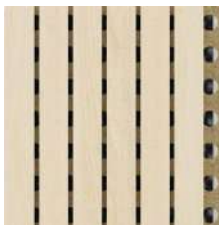

Punching rate 9.0%

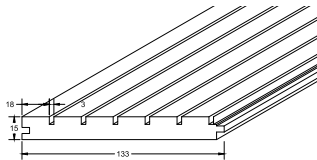

Sound absorption coefficient

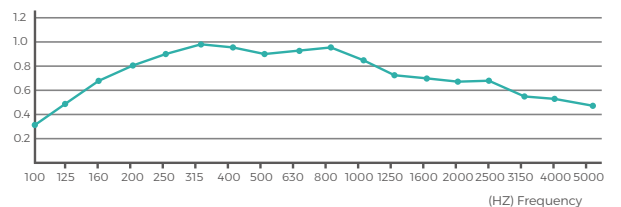

Frequency	100	125	160	200	250	315	400	500	630	800	1000	1250	1600	2000	2500	3150	4000	5000
Sound absorption coefficient	0.38	0.55	0.70	0.80	0.90	0.98	0.98	0.90	0.90	0.88	0.82	0.78	0.70	0.68	0.62	0.55	0.53	0.52

13-3

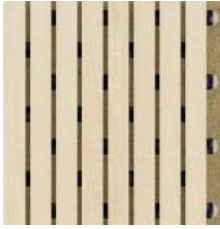

Punching rate 12.0%

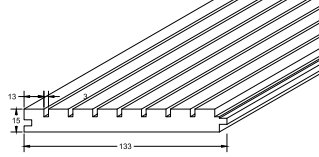

Sound absorption coefficient

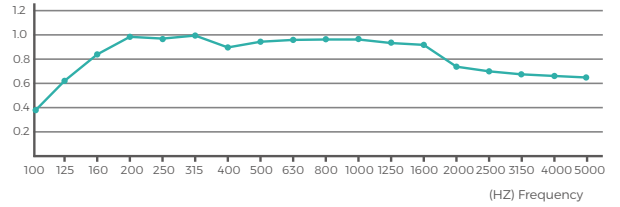

Frequency	100	125	160	200	250	315	400	500	630	800	1000	1250	1600	2000	2500	3150	4000	5000
Sound absorption coefficient	0.39	0.64	0.82	0.99	0.99	1.00	0.90	0.92	0.92	0.98	0.98	0.94	0.86	0.73	0.66	0.66	0.65	0.62

14-2

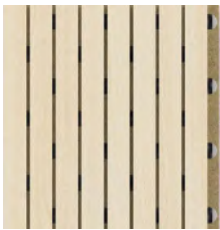

Punching rate 8.0%

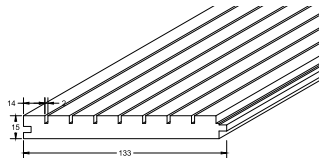

Sound absorption coefficient

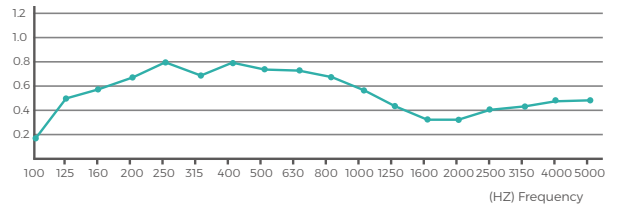

Frequency	100	125	160	200	250	315	400	500	630	800	1000	1250	1600	2000	2500	3150	4000	5000
Sound absorption coefficient	0.20	0.45	0.60	0.70	0.80	0.75	0.82	0.76	0.75	0.62	0.52	0.40	0.37	0.35	0.40	0.40	0.44	0.45

9-2



Punching rate 12.0%

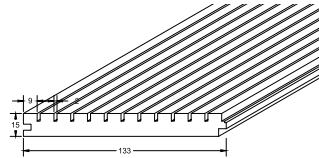

Sound absorption coefficient

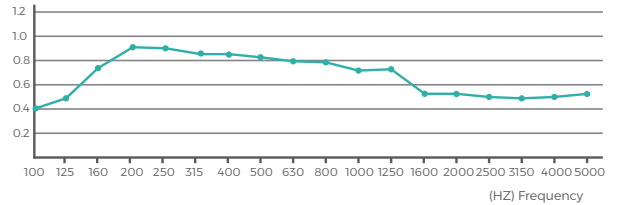

Frequency	100	125	160	200	250	315	400	500	630	800	1000	1250	1600	2000	2500	3150	4000	5000
Sound absorption coefficient	0.40	0.50	0.53	0.70	0.90	0.90	0.87	0.87	0.80	0.80	0.71	0.70	0.58	0.57	0.56	0.48	0.48	0.48

5-3

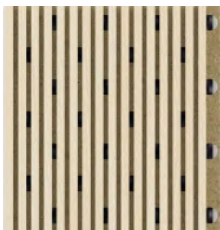

Punching rate 19.0%

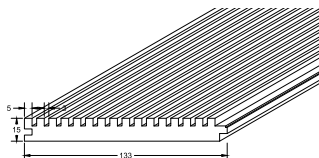

Sound absorption coefficient

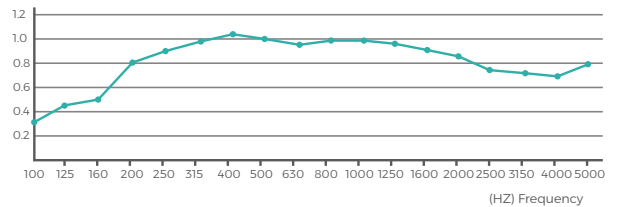

Frequency	100	125	160	200	250	315	400	500	630	800	1000	1250	1600	2000	2500	3150	4000	5000
Sound absorption coefficient	0.32	0.38	0.48	0.80	0.88	0.95	0.95	1.08	1.00	0.95	1.00	1.00	0.95	0.93	0.80	0.79	0.75	0.80

WALL INSTALL METHOD

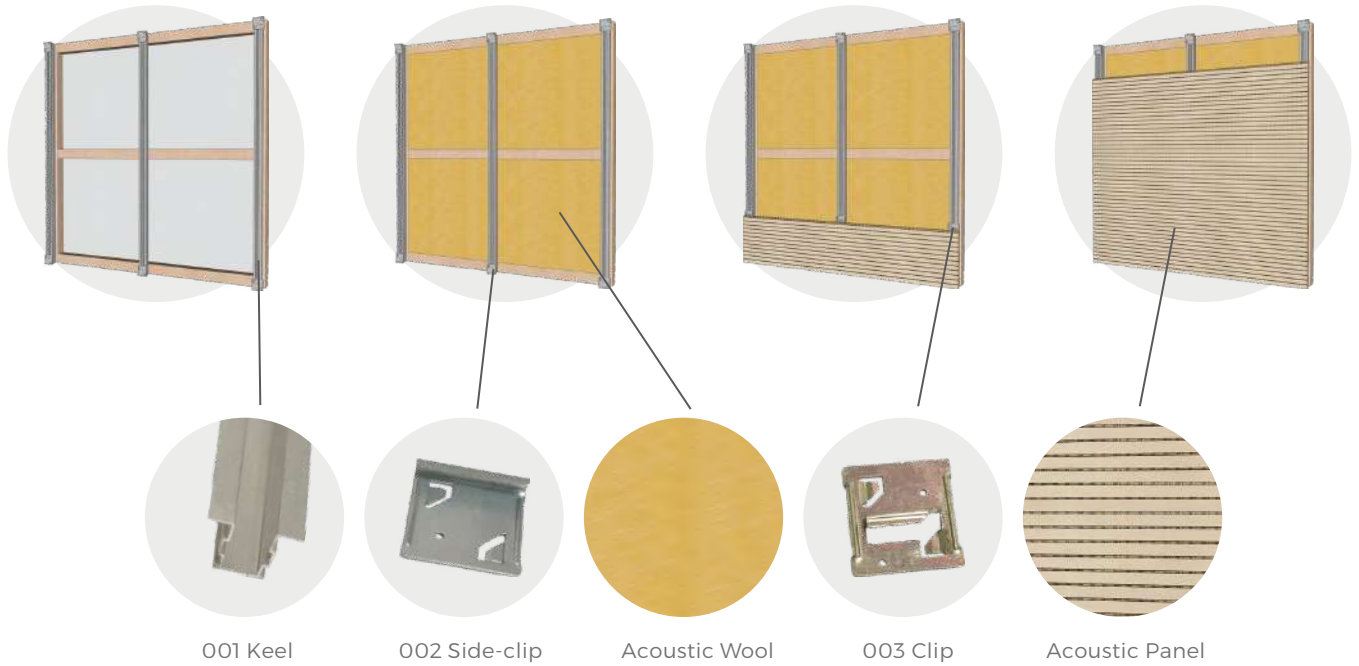

PREPARATION WORK BEFORE INSTALL AND REQUIREMENT IN INSTALL PLACE.

01

The install place should reach the requirement in temperature and humidity in 24 hours before install. The lowest temperature is 15 degree and the range in 40%-60%.

02

Open the carton at least 48 hours before install.

03

Install the wood keel or steel keel as per design drawing and construction draw. The configuration for the keel should be the same as the wood acoustic panel. The recommend distance is 300-600mm.

04

Fill in the fiberglass wool in the gap of keel as per design.



STEEL KEEL AND CLIPS METHOD

1. Fix keel 001 on the wooden battens by gunnail and screw.
2. Clip 002,003 insert into keel 001, pls make sure the wood acoustic panel be fixed
3. Pls install the panels from left to right and from bottom to top.
4. If want adjust the panels, pls adjust the clips 002,003.

PERFORATED ACOUSTIC PANEL PA SERIES

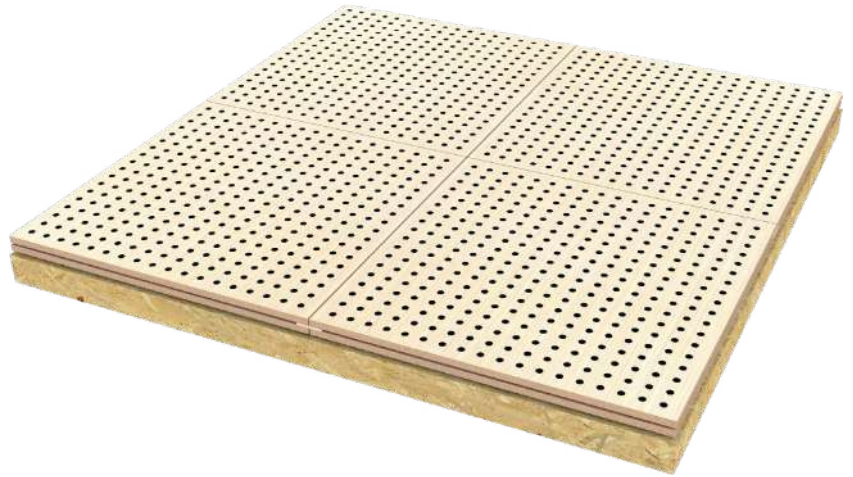

PRODUCT INTRODUCTION

The structure of hole perforation in front and back is based on scientific calculation and acoustic principle. Wooden perforated acoustic panel has high sound absorption performance in low and middle frequency. It has various finish color and materials choice to meet customers diversified request for acoustic and decoration and provide safety promise for environment protection and fire-resistant.

SPECIFICATIONS

Name	Perforated Acoustic Panel
Structure	Base Materials / Finish / Back
Base Materials	Standard / Eco-friendly / Fire-resistant / Moisture-proof / A Grade Non-inflammable / composite Fire-resistant / Non-formaldehyde Solid Wood / Other Customization
Finish	Veneer / Melamine / HPL Fire-proof / Pu Painting
Back	Black Fire-resistant Sound Absorbing Fleece / Soundtex Sound Absorbing Fleece
Model	PAE 16/6/15, E 16/8/15, V 32/6/15, V 16/6/15, E 16/3-10/15, V 32/3-10/15, E 8/1-12/15, E 5/1-12/15, Other customized model
Common Size	W 600mm/1200mm * L 600/1200/2400mm * T 15/18/12mm
Eco-friendly	All materials meet the national and international environmental protection standard. The product contains little formaldehyde with natural wood fragrance. Non-formaldehyde is also available.
Fire-resistant	Fire-resistant panels can reach class A under ASTM-E84 standard, Class1 under BS476 part 7 standard.

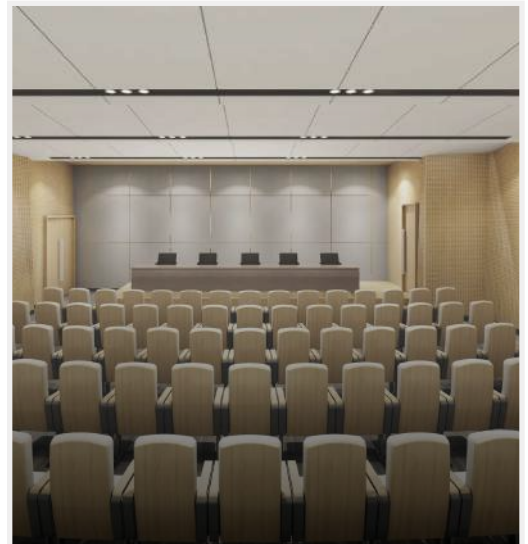
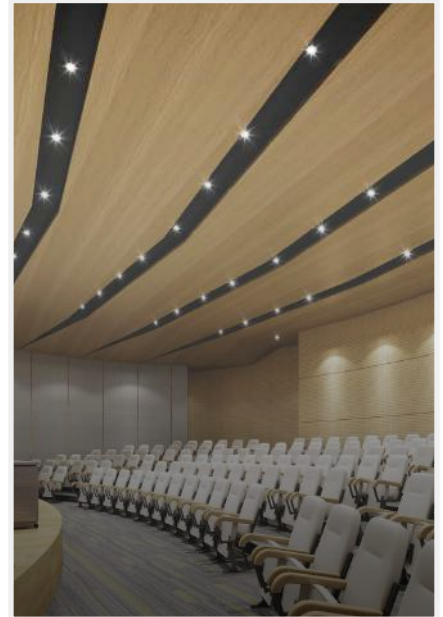

APPLICATION

Multifunctional hall, conference room, opera hall, cinema, auditorium, hotel, TV station, Music hall, piano room, gymnasium, villa, or any place which has high acoustic request.

E16/6

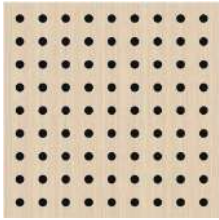

Punching rate 11%

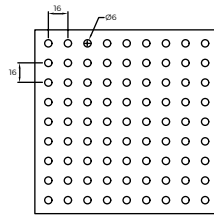

Sound absorption coefficient

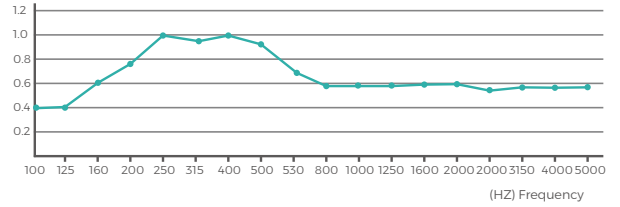

Frequency	100	125	160	200	250	315	400	500	630	800	1000	1250	1600	2000	2500	3150	4000	5000
Sound absorption coefficient	0.40	0.40	0.60	0.82	0.79	1.00	0.98	1.00	0.90	0.65	0.58	0.60	0.60	0.60	0.58	0.59	0.59	0.59

E16/8

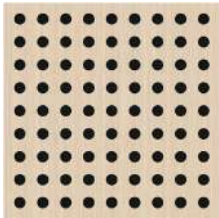

Punching rate 20%

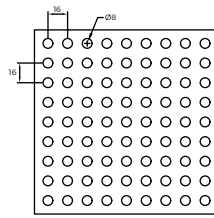

Sound absorption coefficient

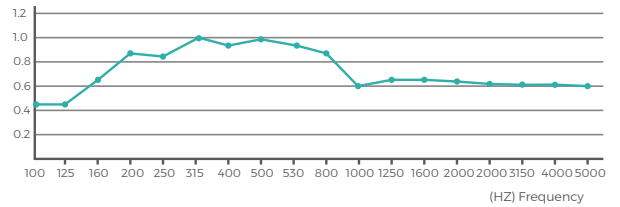

Frequency	100	125	160	200	250	315	400	500	630	800	1000	1250	1600	2000	2500	3150	4000	5000
Sound absorption coefficient	0.42	0.42	0.65	0.85	0.82	1.00	0.98	1.00	0.95	0.75	0.60	0.70	0.70	0.68	0.62	0.62	0.61	0.60

V32/6



Punching rate 6%

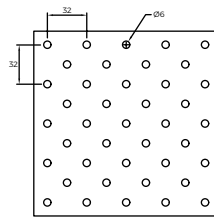

Sound absorption coefficient

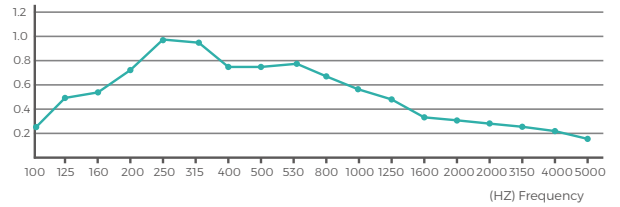

Frequency	100	125	160	200	250	315	400	500	630	800	1000	1250	1600	2000	2500	3150	4000	5000
Sound absorption coefficient	0.28	0.53	0.57	0.76	0.86	0.98	0.95	0.78	0.75	0.77	0.64	0.58	0.46	0.38	0.36	0.28	0.23	0.18

E16/6

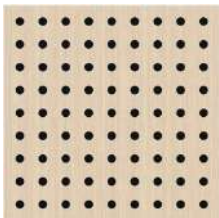

Punching rate 22%

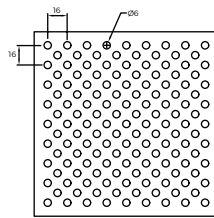

Sound absorption coefficient

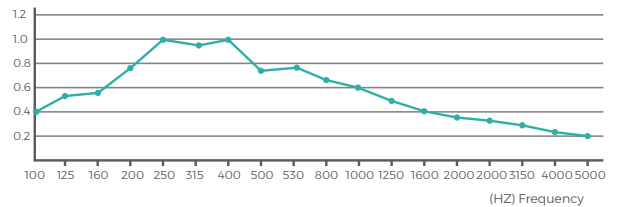

Frequency	100	125	160	200	250	315	400	500	630	800	1000	1250	1600	2000	2500	3150	4000	5000
Sound absorption coefficient	0.30	0.55	0.59	0.78	0.88	1.00	0.97	0.80	0.77	0.79	0.66	0.60	0.48	0.40	0.38	0.30	0.25	0.20

E16/3-10

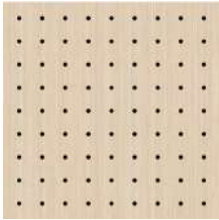

Punching rate 3%

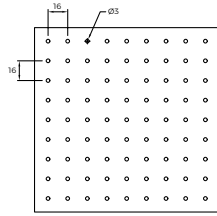

Sound absorption coefficient

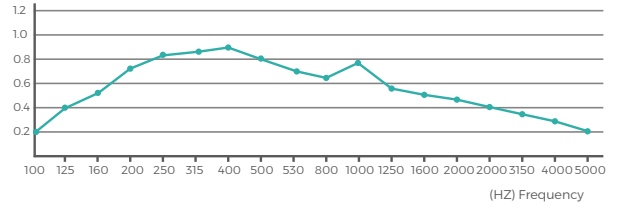

Frequency	100	125	160	200	250	315	400	500	630	800	1000	1250	1600	2000	2500	3150	4000	5000
Sound absorption coefficient	0.20	0.40	0.50	0.70	0.83	0.97	0.98	0.90	0.80	0.70	0.67	0.78	0.58	0.48	0.40	0.38	0.28	0.20

V16/8

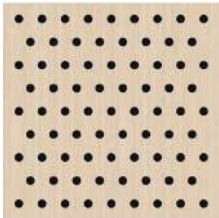

Punching rate 1.4%

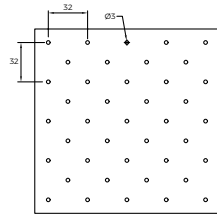

Sound absorption coefficient

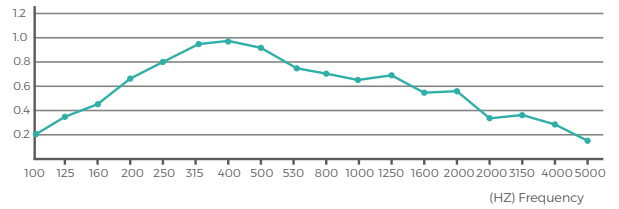

Frequency	100	125	160	200	250	315	400	500	630	800	1000	1250	1600	2000	2500	3150	4000	5000
Sound absorption coefficient	0.18	0.38	0.48	0.68	0.81	0.95	0.96	0.88	0.75	0.68	0.65	0.76	0.56	0.46	0.38	0.36	0.26	0.18

E8/1-12

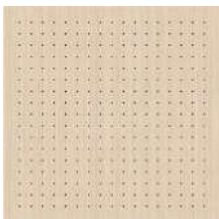

Punching rate 2%

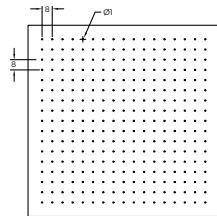

Sound absorption coefficient

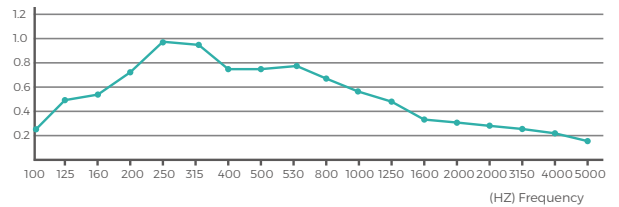

Frequency	100	125	160	200	250	315	400	500	630	800	1000	1250	1600	2000	2500	3150	4000	5000
Sound absorption coefficient	0.30	0.40	0.50	0.80	0.78	0.85	0.82	0.72	0.68	0.61	0.57	0.40	0.37	0.27	0.20	0.18	0.17	0.16

E5/1-12

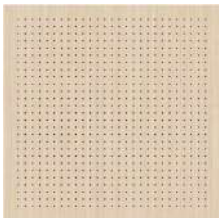

Punching rate 3.2%

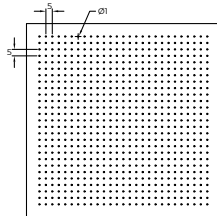

Sound absorption coefficient

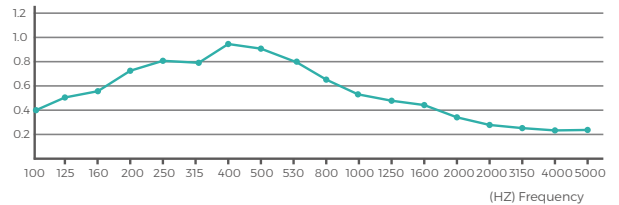

Frequency	100	125	160	200	250	315	400	500	630	800	1000	1250	1600	2000	2500	3150	4000	5000
Sound absorption coefficient	0.30	0.42	0.55	0.75	0.82	0.80	0.92	0.90	0.80	0.61	0.52	0.50	0.45	0.35	0.30	0.26	0.24	0.24

MICRO-PERFORATED ACOUSTIC WOOD PANEL

APPLICATION

Opera house, movie theater, recording studio, broadcasting room, TV station, radio station, business office, multi-function hall, meeting room, studio, concert hall, auditorium, gymnasium wall.

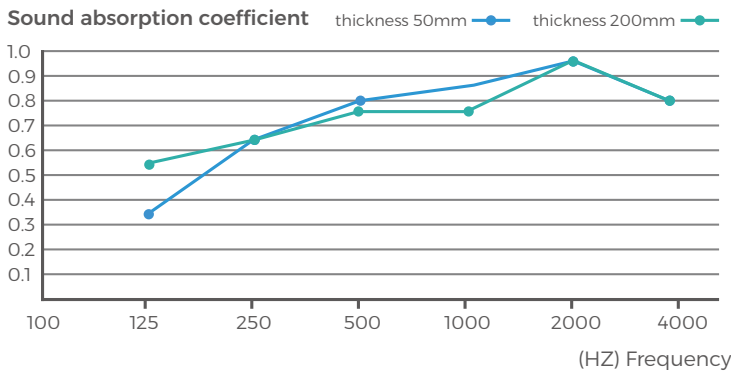

Frequency	125	250	500	1000	2000	4000
Plenum 50mm	0.38	0.65	0.80	0.85	0.95	0.80
Plenum 200mm	0.38	0.65	0.75	0.75	0.95	0.80

PRODUCT INTRODUCTION

Micro-perforated acoustic wood panels are manufactured on fibreboard panels (MDF) with microperforations on the visible side and big holes in the back side to improve absorption coefficient of the panels. It has strong selectivity to the sound absorption spectrum and has a good sound absorption effect in the middle and low frequency bands. If the cavity behind the sound-absorbing structure is filled with an appropriate amount of wall or ceiling decoration.

SPECIFICATIONS

Name	0.5mm Micro-perforated Acoustic Wood Panel
Model	1.8-1.8-0.5, 4-4-0.5, 2-2-0.5, 2.2-2.2-0.5 (hole diameter: 0.5mm)
Finish	Melamine, Technical Veneer, Natural Veneer, Fireproof Leather, Etc.
Common Size	W 600mm/1200mm * L 600/1200/2400mm * T 15/18/12mm

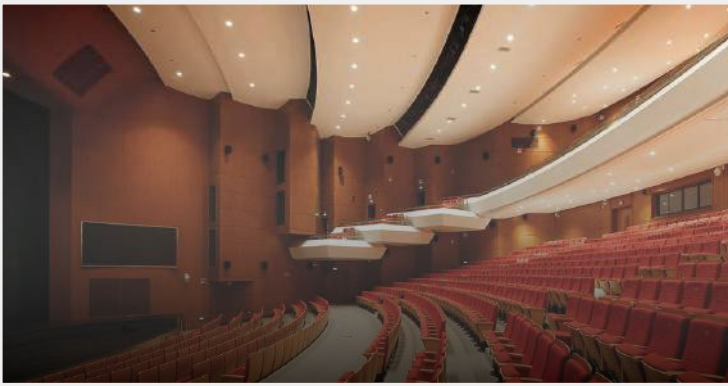

ART ACOUSTIC PANEL AA SERIES



PRODUCT INTRODUCTION

As society develops, the request of customers becomes more and more precise and exquisite. Art acoustic panels have an artistic shape, unique and natural design, original natural wood finish, environmental and safety materials, high sound absorbing performance. All these features attract many customers and designers to choose it.

SPECIFICATIONS

Name	Art Acoustic Panel
Structure	Base Materials / Finish / Back
Base materials	Eco-friendly / Fire-resistant/Moisture-proof / Non-formaldehyde Solid Wood / Black HDF / Other Customization.
Finish	Veneer / Melamine
Back	Black fire-resistant sound absorbing fleece / Soundtex sound absorbing fleece
Model	Refer to photo
Common size	W 600/1200mm * L 600/1200/2400mm * T 15/18/12mm or any other size

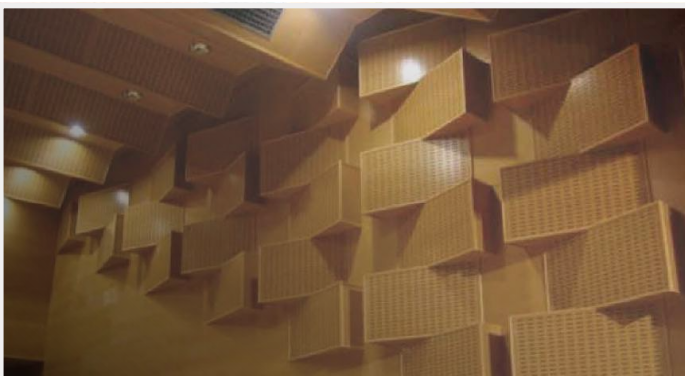

MODELS



ACO-A01

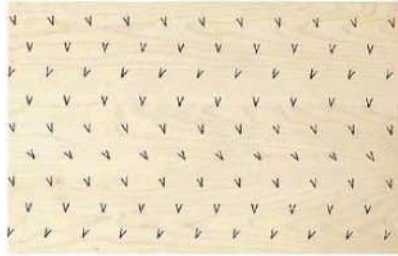

ACO-A02



ACO-A03



ACO-A04



ACO-A05



ACO-A06



ACO-A07



ACO-A08

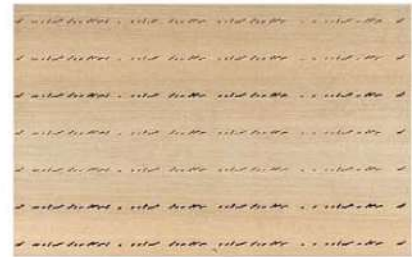

ACO-A09



ACO-A10



ACO-A11

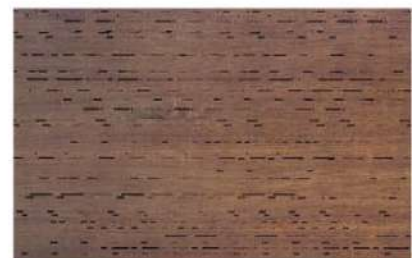

ACO-A12

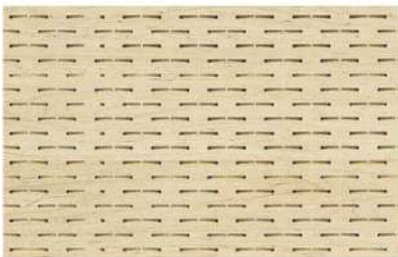

ACO-A13

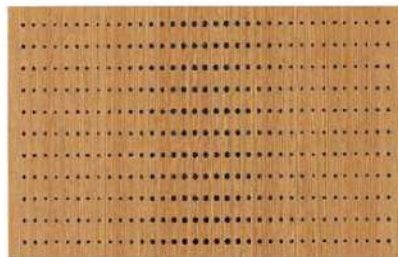

ACO-A14

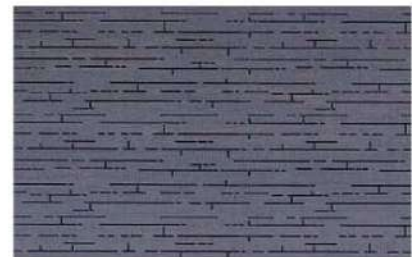

ACO-A15



ACO-A16

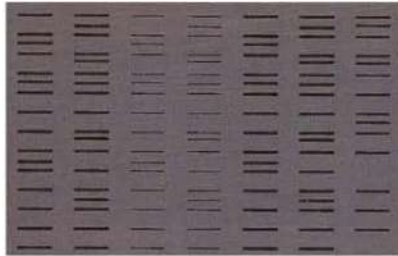

ACO-A17

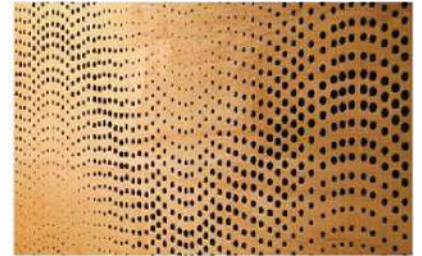

ACO-A18



ACO-A19

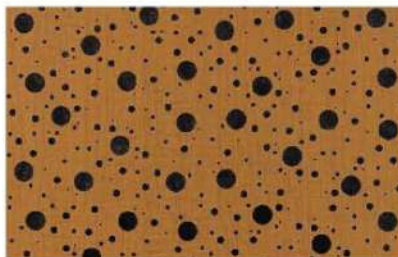

ACO-A20

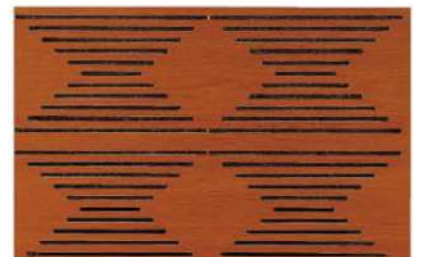

ACO-A21

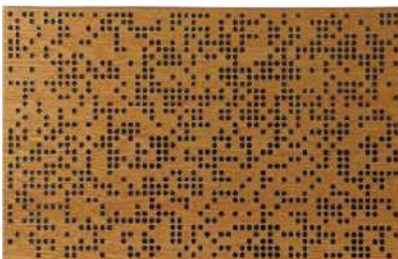

ACO-A22



ACO-A23

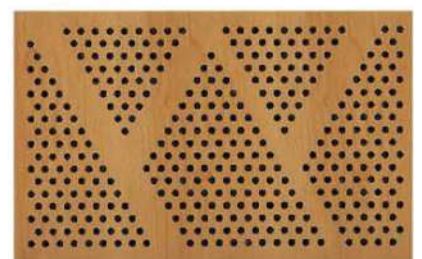

ACO-A24

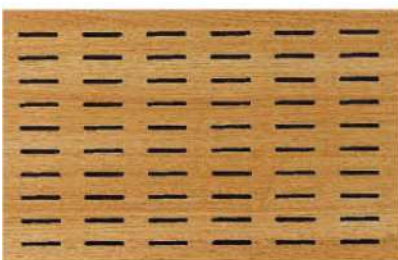

ACO-A25

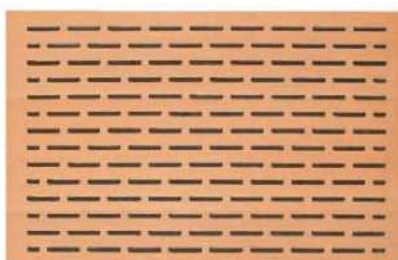

ACO-A26

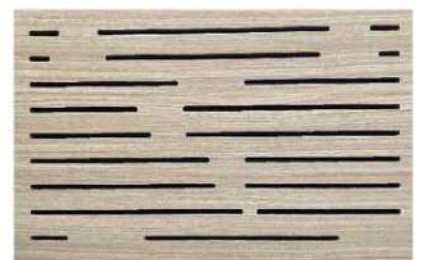

ACO-A27



ACO-A28

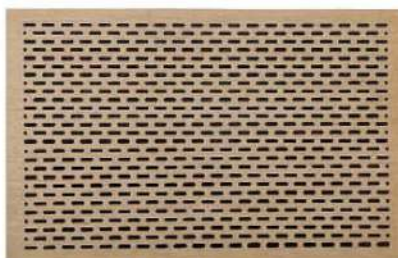

ACO-A29



ACO-A30

PERFORATED AND ART ACOUSTIC **PANEL KEEL SYSTEM(KS)SERIES**

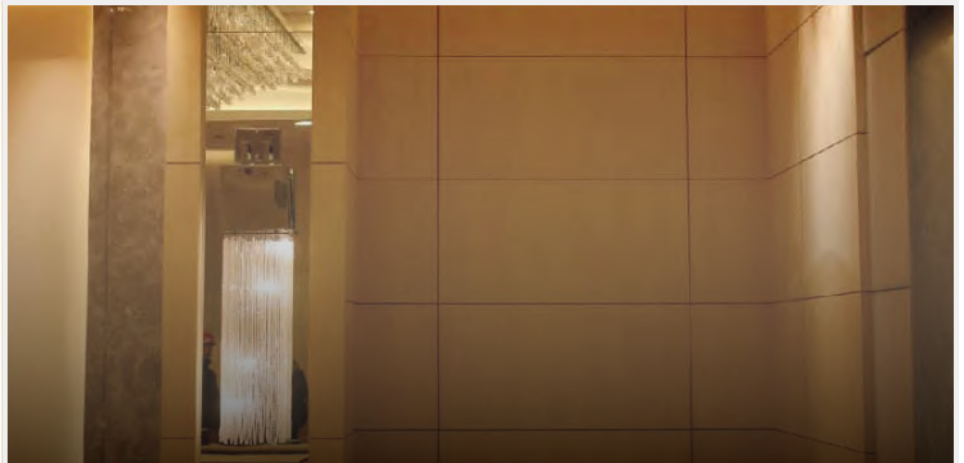
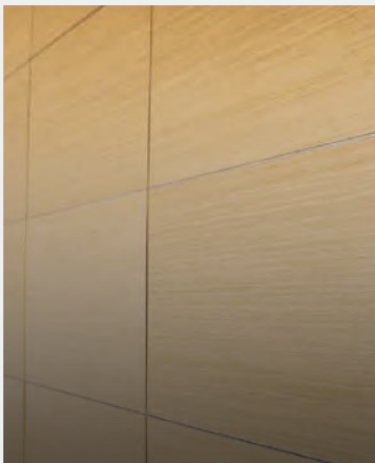
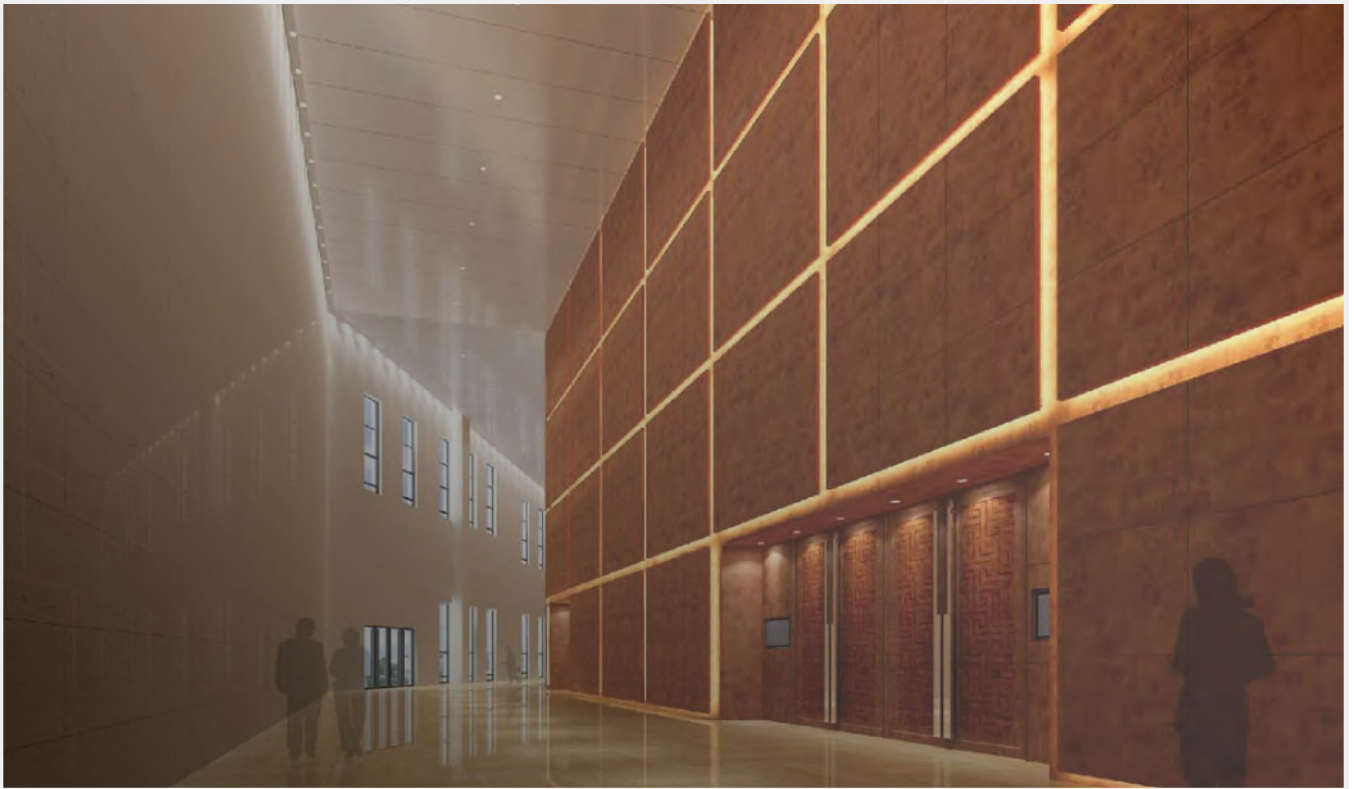

WALL INSTALL SYSTEM

KEEL SYSTEMS INSTALL METHOD

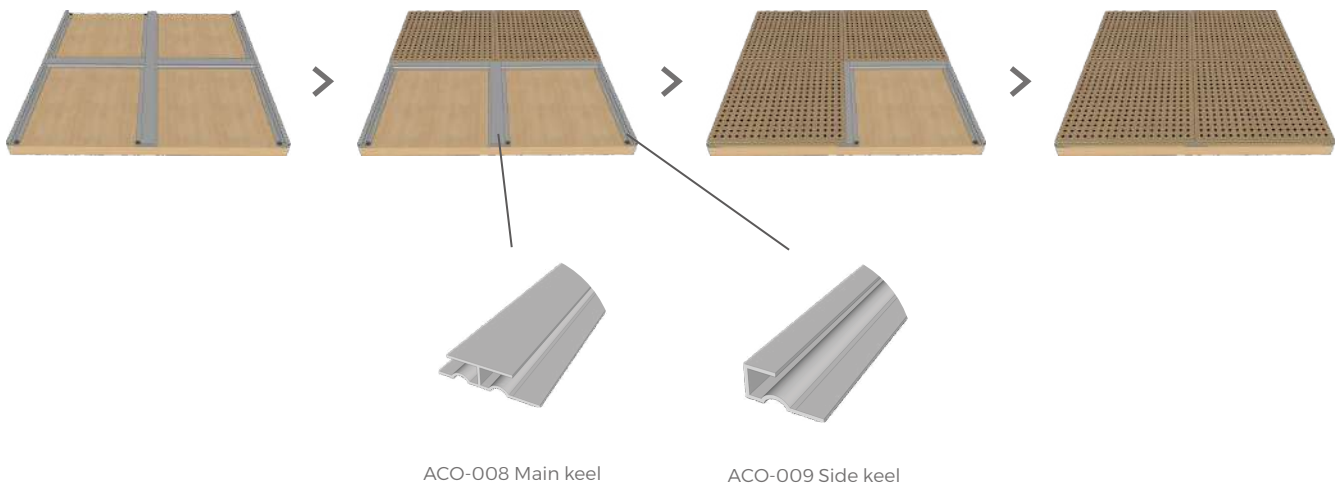

Fix main keel ACO-008 on the wood battens and light steel keel by gunnail and screw.

Fix the ACO-009 side keel in the end of install area.

The groove move along ACO-008 and ACO-009 direction from left to right and bottom to top.

Solid and natural veneer has request for texture. we will mark numbers on the back. Pls install it from small number to big.

KEEL AND CLIPS INSTALL METHOD

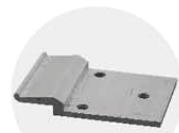
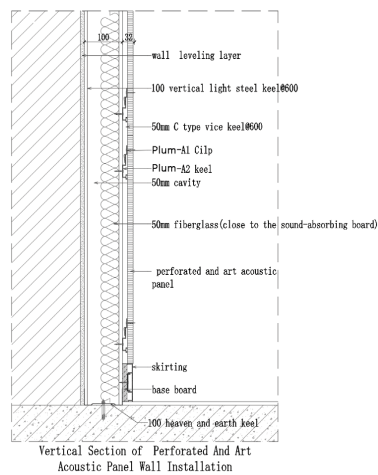

ACO-A1 Clip

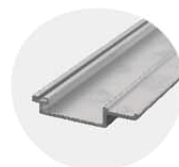

ACO-A2 keel

WOOD SLAT INSTALL METHOD

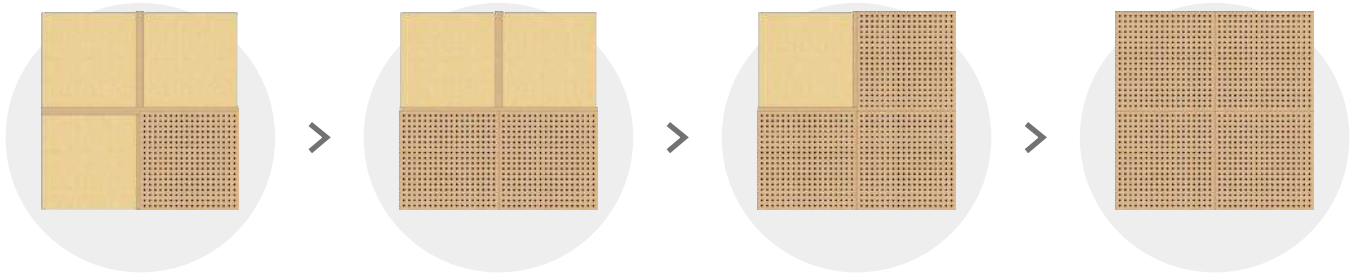

CEILING INSTALL SYSTEM

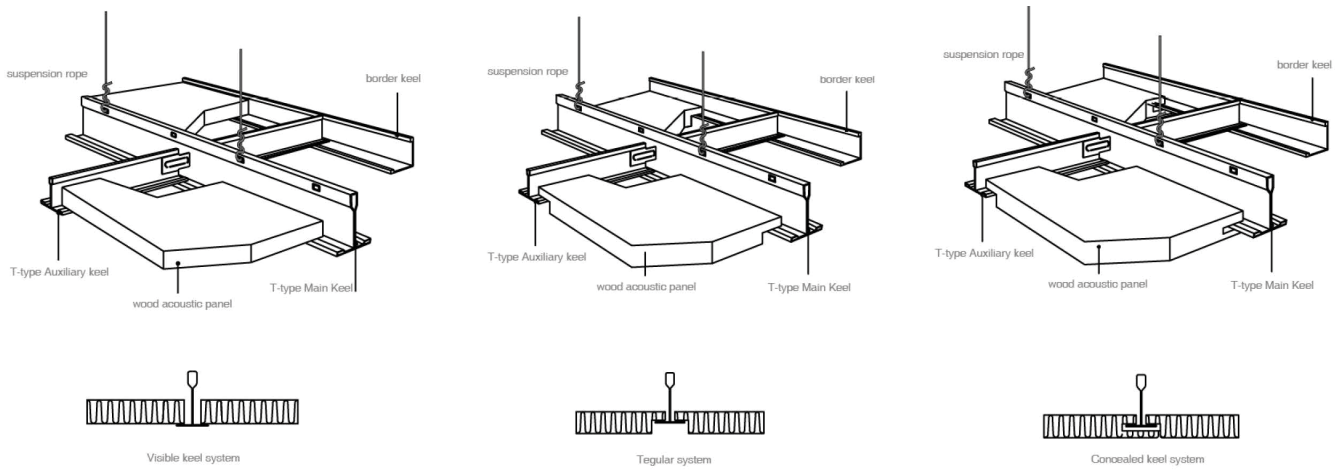

BASE MATERIALS

MDF SERIES



Standard MDF



Pine Eco-Friendly MDF



Red Fire-Resistant MDF



Black MDF



Green Moisture-Proof
MDF

MGO COMPOSITE FIRE-RESISTANT SERIES



Composite Board



A Grade Mgo Board



A Grade Black Mgo
Board



A Grade Mgo Composite
Board



Composite Board

NON-FORMALDEHYDE SERIES



Original Bamboo Board



Carbonized Bamboo
Board



Oak Solid Wood



Pine Solid Wood



Multilayer Solid Wood

HPL Finish



Melamine Finish

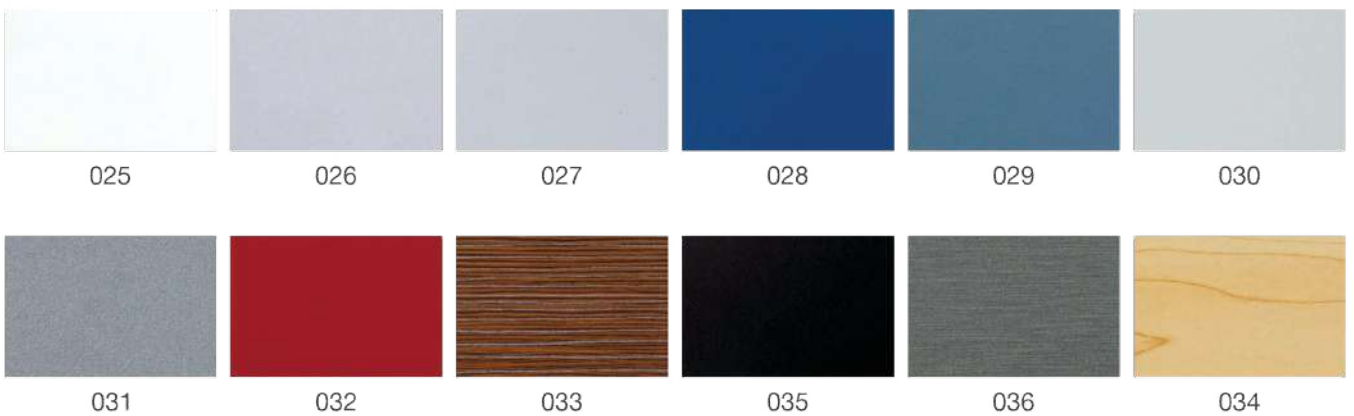



037

038

039

040

041

042



043

044

045

046

047

048



049

050

051

052

053

054



055

056

057

058

059

060



061

062

063

064

065

066



067

068

069

070

071

072

FABRIC ACOUSTIC PANEL

FA SERIES

PRODUCT INTRODUCTION

Fabric acoustic panel is made of Eco-solidify frame aluminum frame and wood frame, filled with high density non-inflammable icro-perforated fiberglass acoustic board, covering fire-resistant fabric. It is eco-friendly, good decoration fire-resistant no-dusty easy to install The fabric acoustic panel is good materials and high sound absorption performance in middle and high frequency.



FEATURES

1. High performance in sound absorption in middle and high frequency, fire-resistant, no-dusty, good decoration, easy to install.
2. Various color for optional, customized color is acceptable. fabric and frame can change as per customers request.

APPLICATION

Multi-function hall, opera house, conference room, theater, auditorium, hotel television, concert hall, piano room, gymnasium, villa or home life in the strict requirements of acoustics.

SPECIFICATIONS

Name	Fabric Acoustic Panel
Structure	Base Materials finish frame
Base Materials	96kg/m ³ Micro-perforated Fiberglass Acoustic Board Or Other Density Cloth / Leather
Frame	Eco-solidify Frame / Aluminum frame / Soft frame
Shape	Square / Circle / Hexagon / Triangle etc.
Edge	Straight chamfer / Small Chamfer / Big Chamfer
Common Size	W 600/1200mm *L 600/1200/2400mm * T 25/50mm and other design
Fire-resistant	Fire-resistant Panels Can Reach Class A Under ASTM-E84 Standard Class 1 Under Bs476 Part 7 Standard

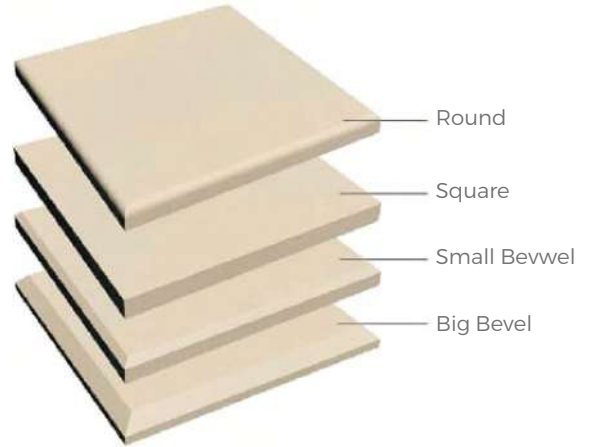
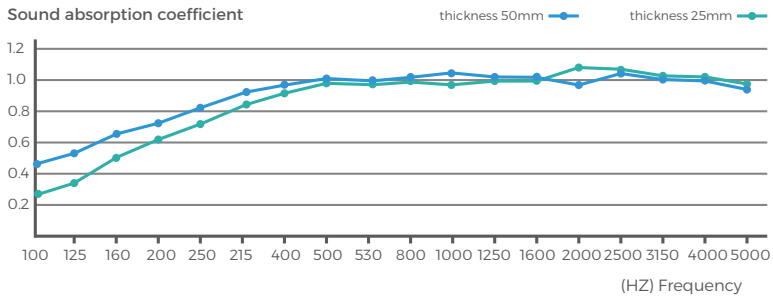

Fabric sound-absorbing board Thickness 25mm

Frequency	100	125	160	200	250	315	400	500	630	800	1000	1250	1600	2000	2500	3150	4000	5000
Sound Absorption Coefficient	0.30	0.38	0.49	0.62	0.73	0.86	0.94	1.03	1.04	1.06	1.08	1.05	1.07	1.12	1.06	1.02	1.00	0.97

Fabric sound-absorbing board Thickness 50mm

Frequency	100	125	160	200	250	315	400	500	630	800	1000	1250	1600	2000	2500	3150	4000	5000
Sound Absorption Coefficient	0.42	0.55	0.63	0.72	0.82	0.88	0.96	1.03	1.04	1.03	1.08	1.07	1.06	1.00	1.02	1.00	0.96	0.96

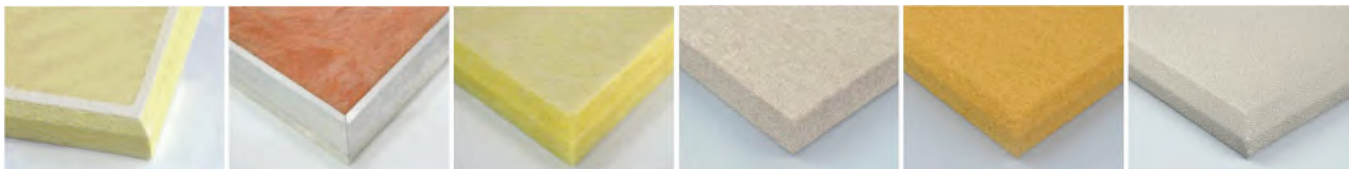

Eco-solidify Frame

Aluminum Frame

Soft Frame

Straight chamfer

Small chamfer

Big chamfer

CLIPS INSTALL METHOD

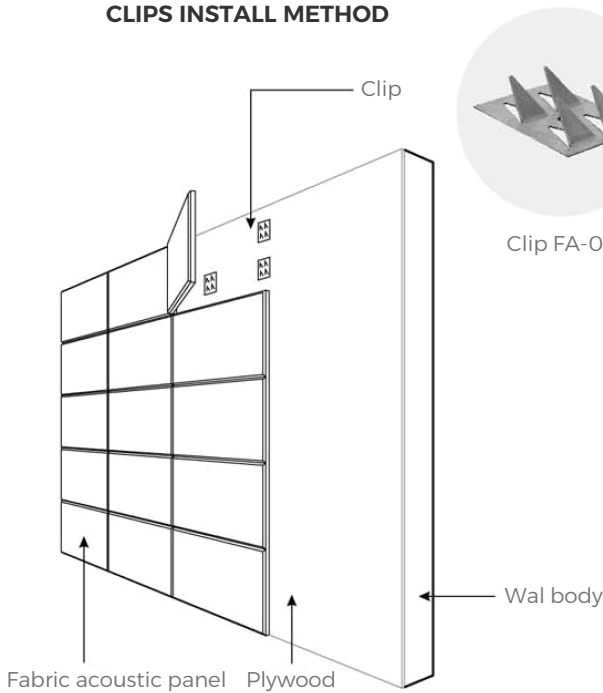

GUN NAIL INSTALL METHOD

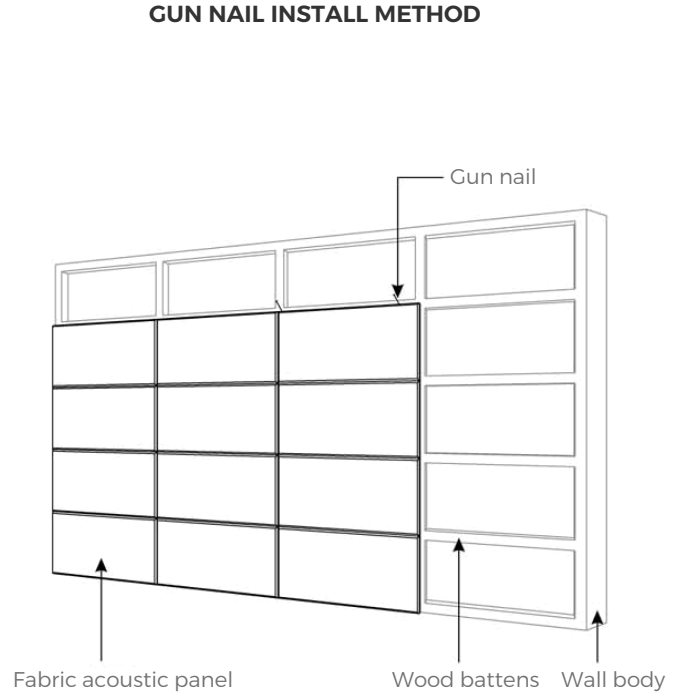

FABRIC ACOUSTIC PANEL INSTALLATION

NODE DRAWING

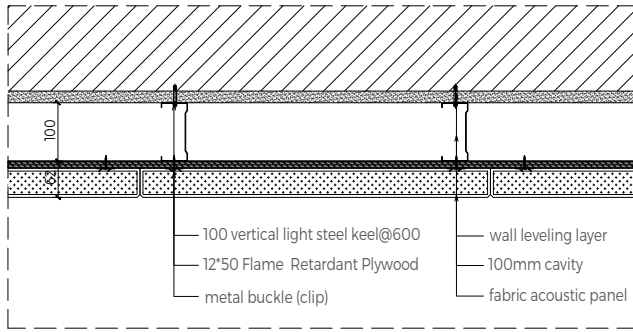

Cross Section of Fabric Acoustic Panel Installation

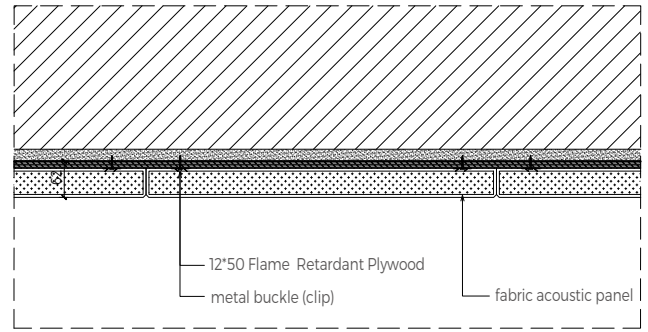

Cross Section of Fabric Acoustic Panel Installation

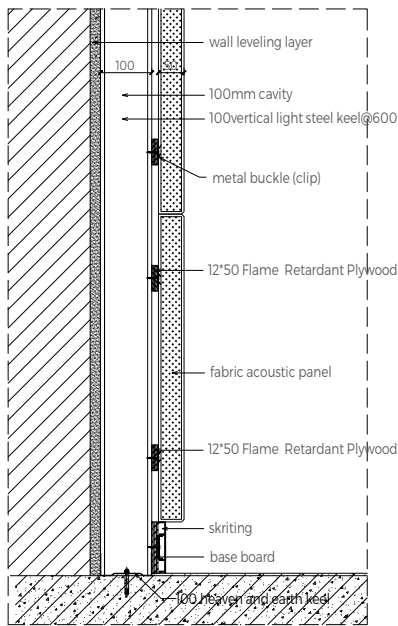

Vertical Section of Fabric Acoustic Panel Wall Installation

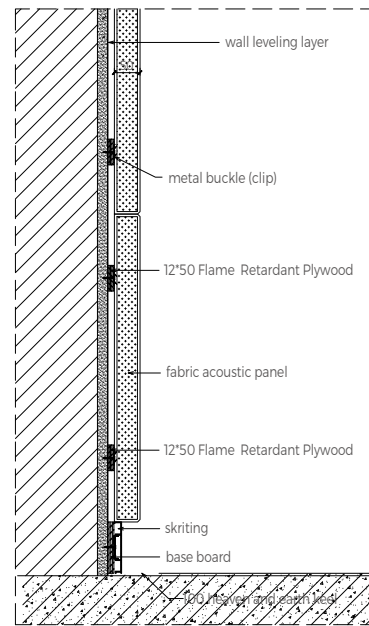

Vertical Section of Fabric Acoustic Panel Wall Installation

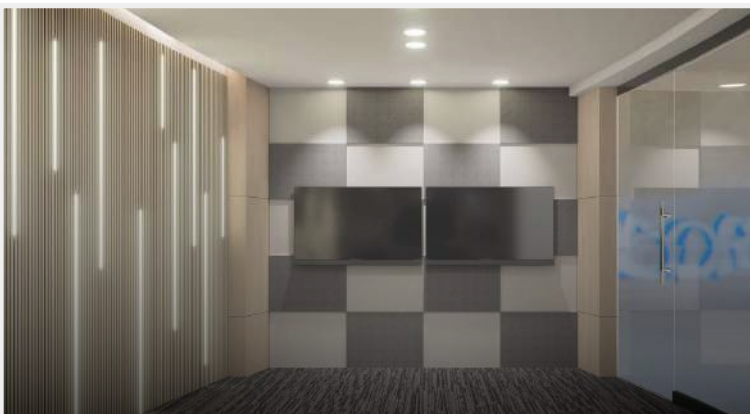

XY130 SERIES (PRESSABLE)

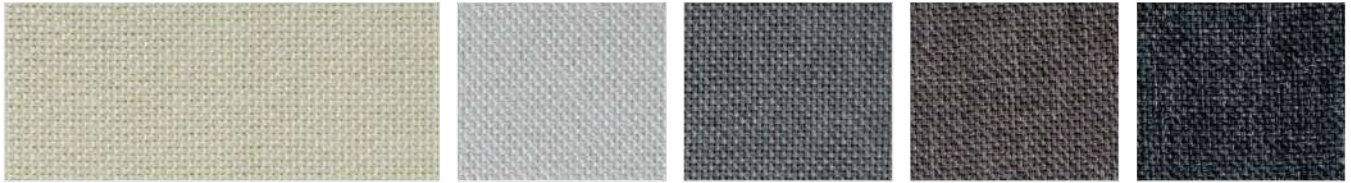

XY130-02

XY130-01

XY130-03

XY130-04

XY130-05

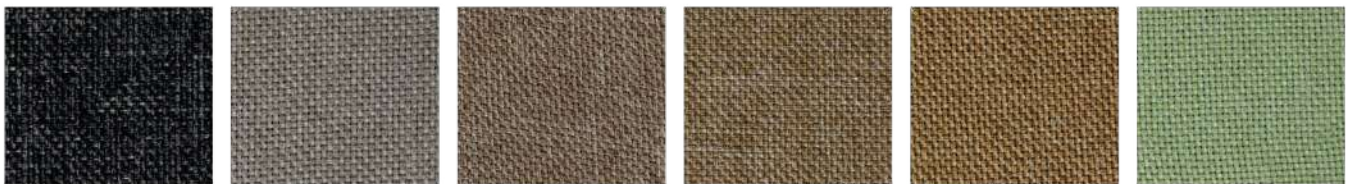

XY130-06

XY130-07

XY130-08

XY130-09

XY130-10

XY130-11



XY130-13

XY130-16

XY130-18

XY130-19

XY130-20

XY130-25



XY130-29

XY130-32

XY130-33

XY130-34

XY130-37

XY130-38

XY147 SERIES (PRESSABLE)



XY147-02

XY147-03

XY147-04

XY147-05

XY147-06



XY147-01

XY147-07

XY147-08

XY147-09

XY147-10

XY147-18



D SERIES

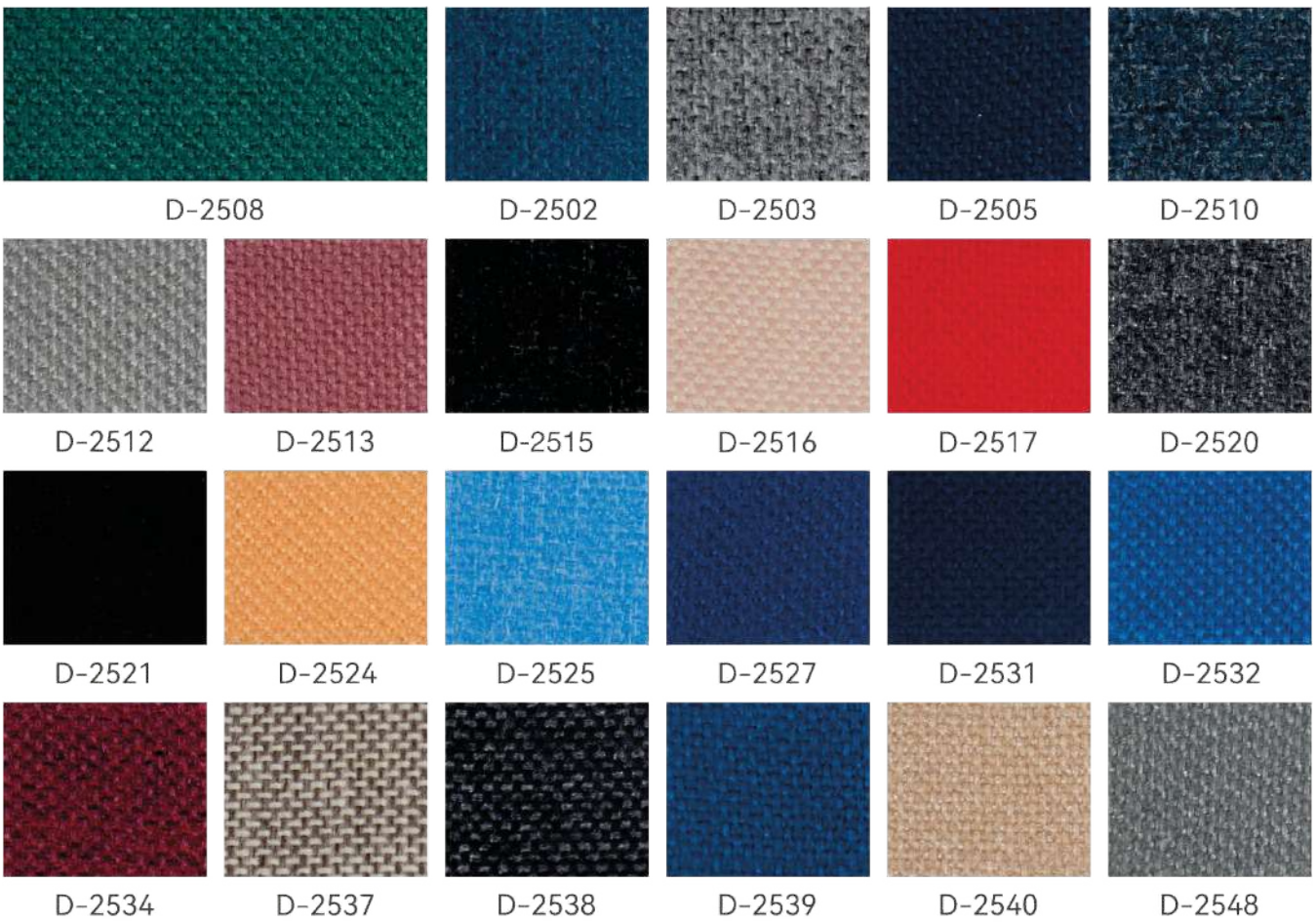

M SERIES



LEATHER SERIES





SUSPEND SOUND

ABSORBER SA SERIES

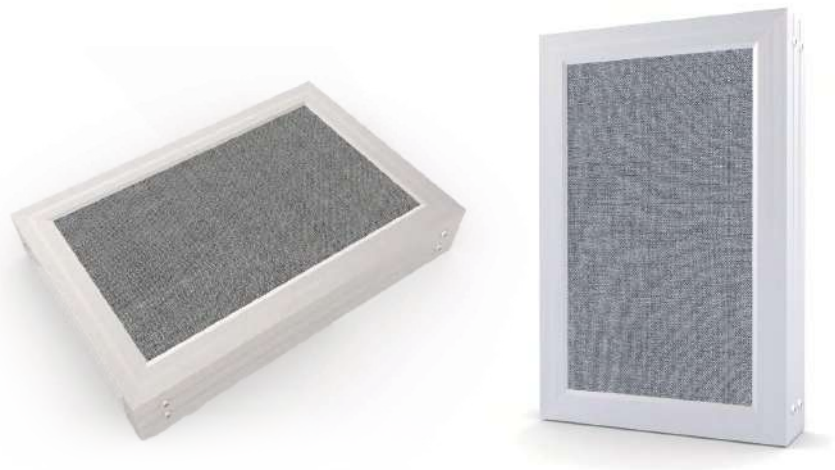

PRODUCT INTRODUCTION

These places such as gymnasium, great opera hall and dancing hall will use Suspended sound absorber for architectural acoustic design and keeping architectural style. Suspended sound absorber is a kind of high sound absorbing performance acoustic materials which hang in the top. It is always in vertical hanging and horizontal hanging. When the suspended sound absorber cover 30%-45% of top area, the sound absorbing performance is two times than others. It also used for industry factory noise reduction.

SPECIFICATIONS

Name	Suspended Sound Absorber
Structure	Base Materials, Finish, Frame
Base Materials	80kg/m ³ And 96kg/m ³ Fiberglass Acoustic Board.
Finish	Fire-resistant Fabric / Leather / Fiberglass Cloth
Border	Aluminium Alloy / Eco-solidify / Wood
Model	SA01 50 / SA01 100 / SA01 150
Weight	5.5kg/m ³ / 11.5kg/m ³ / 13.5kg/m ³
Common Size	W 600/1200mm * L 600/1200/2400mm * T 50/100/150mm and other customized
Fire-resistant	Fire-resistant panels can reach class A under ASTM-E84 standard, Class 1 under BS476 part 7 standard.
Eco-friendly	Environmental protection standard. The product contains little formaldehyde with natural wood fragrant. Non-formaldehyde is also available.
Application	Stadium, multi-functional hall and some big space.

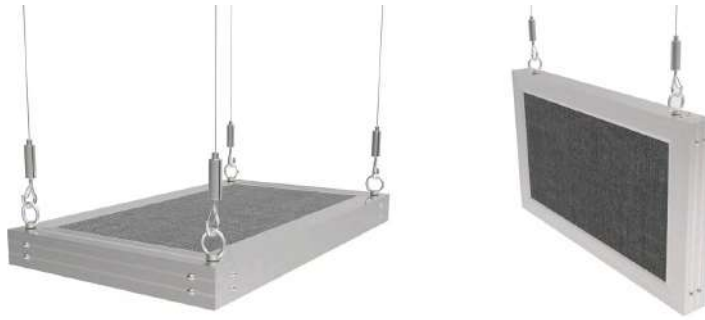

SA01



SA02



SA03



SA04



SA05



SA06



SA07



SA08



SA09

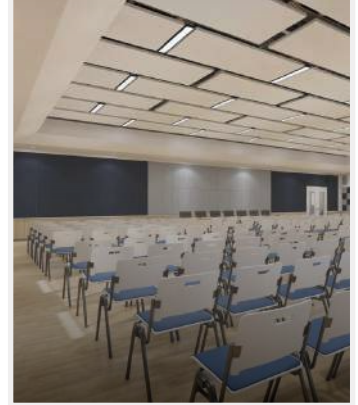

SOUND ABSORBING COTTON BAG

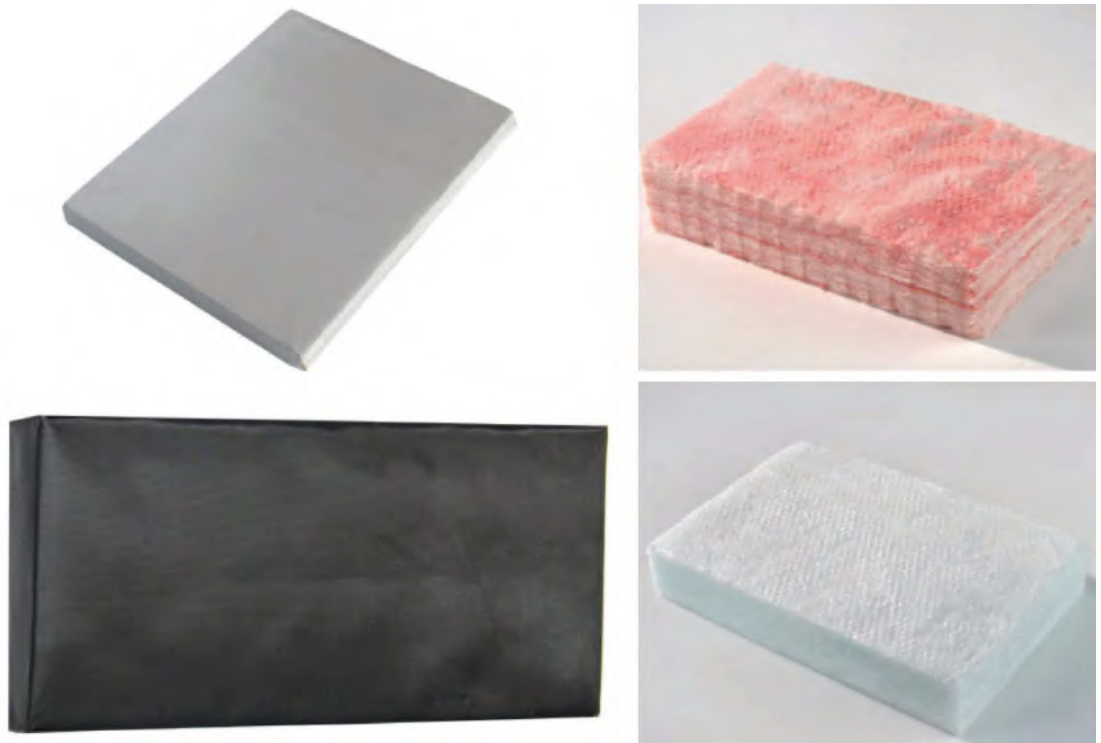

SPECIFICATIONS

Installation Position	Installed behind the sound absorbing material as filling material
Color	White or black
Structure	Owens Corning wool , hydrophobic & formaldehyde free white glass wool wrapped with 100g--200g/m ² white glass fiber cloth.
Fire Resistance	Class A
Size	Length: 1200mm/2400mm Width: 600mm/1200mm Thickness: 25mm/50mm/80mm/100mm (Tolerance: length±2mm, width±1mm, thickness±1mm)
Applicable Place	It is suitable for strengthening the sound absorption performance in the back cavity of various sound absorption materials, such as grooved aluminum acoustic panel, grooved acoustic panel, perforated acoustic panel, perforated aluminum panel and crystal-ACOD acoustic panel etc.

WOOD WOOL ACOUSTIC PANEL WA SERIES

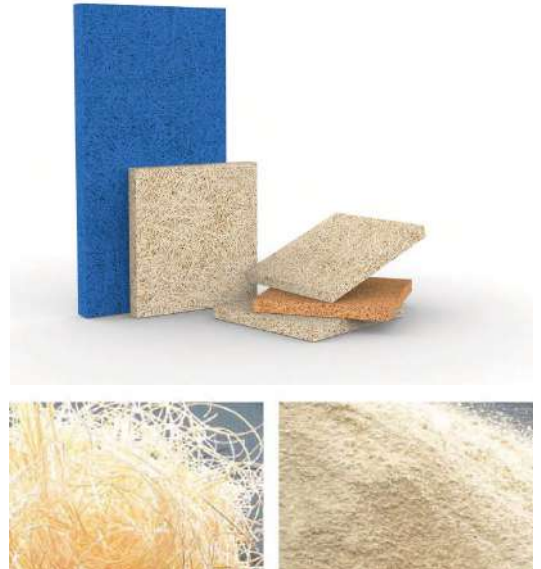
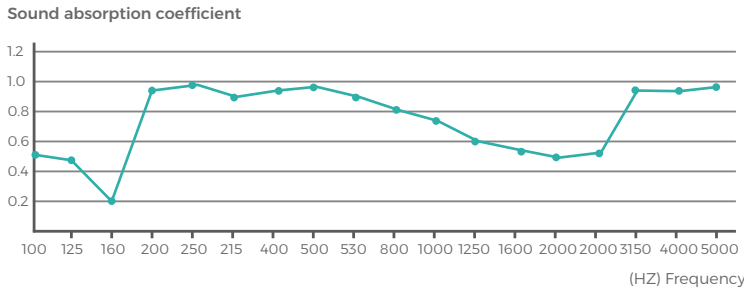

PRODUCT INTRODUCTION

Wuyang wood wool acoustic panels are made from high-quality pine and fir logs, air-dried for at least three months and bonded with inorganic concrete. They are produced under high temperature and pressure, offering excellent acoustic performance and thermal insulation. Available in both painted and natural finishes, these panels provide striking decorative effects. Ideal for both indoor and outdoor use, they meet sound absorption and insulation requirements. With a unique texture, they showcase creativity and combine the benefits of wood and concrete—light as wood, strong as concrete. Features include sound absorption, fireproof, impact-resistant, mildewproof, and moistureproof properties. These panels are perfect for spaces like gyms, theaters, cinemas, meeting rooms, churches, schools, libraries, and natatoriums.

FEATURES

Wood wool acoustic panel is made of natural wood fiber, integrated with unique inorganic concrete bond, cranked out under high temperature and pressure finally. It has perfect physical characters which can only get from combination of different building materials and unique appearance. excellent sound absorption character. The special appearance texture gives you a natural feeling which meet the idea that back to nature.

SPECIFICATIONS

Name	Wool Wood Acoustic Panel(WWCB)
Structure	Base Materials / Finish
Base Materials	Wood Fiber And Inorganic Cement
Finish	Primary colour and sprayed colour
Common Size	W 600/1200/1220mm * L 600/1200/2440mm * T 15/20/25mm

ART WOOD WOOL ACOUSTIC PANEL

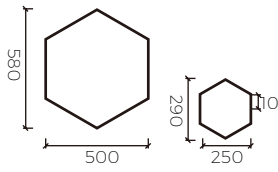

ACO-H
Hexagon

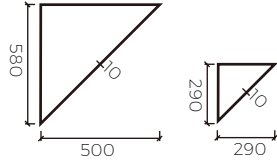

ACO-T
Triangle

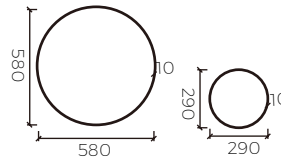

ACO-C
Circle

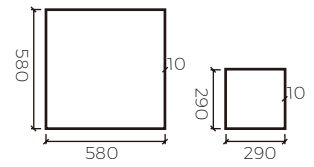

ACO-S
Square

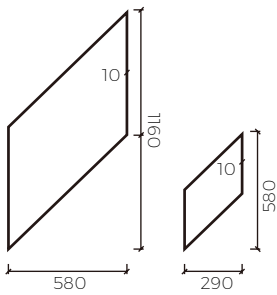

ACO-R
Rhombus

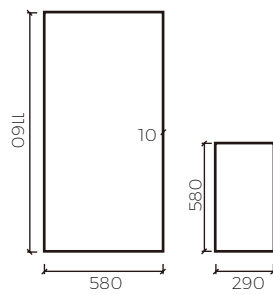

ACO-Re
Rectangle

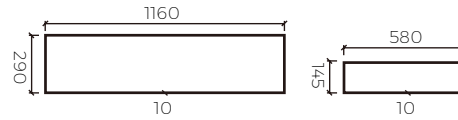

ACO-St
Strip

INSTALLATION METHOD

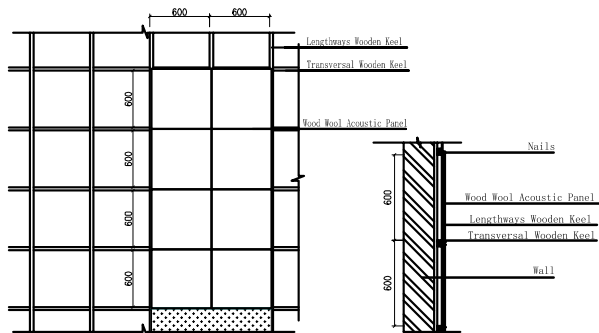

Wood Wool Acoustic Panel Wall Installation

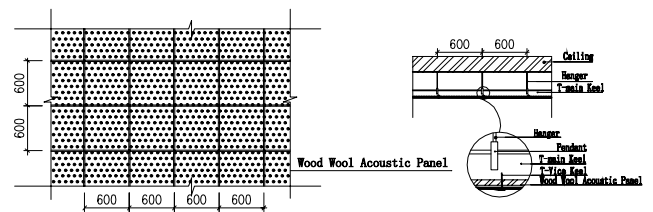

SPECIFIC FEATURES



Sound Absorption and Sound Insulation: wood wool acoustic panels sound absorption rate is between 0.9 and 1.0 tested by authoritative organization.



Thermal Insulation: Since the main material is wood fiber which is a poor conductor of heat, the wood wool acoustic panel has a very small thermal conductivity.



Moisture Proof and Mildew Proof: Appearance of wood fiber is protected by cement and mineralized which is not conductive to insects, mites, termites and other habitats and away mold.



Fire Resistance: wood wool acoustic panel is fire-resistance materials. The greater capacity, the better fire resistance Fireproof as B grade according to GB8624-2006 and A2 grade according to GB8624-2006.



Green Environment-friendly: ACO wood wool acoustic panel is made of pine and fir logs, and processed by sustainable raw materials. Formaldehyde affranchise reach E1 grade, thermal insulation up to 70%.



Rigidity: High impact resistance, through the national authoratative drop hammer strength testing, will never break under impact of football, basketball or valleyball in Olympic Sports Center Gymnasium.



Durability: High-strength materials against externalcontamination, achieved the longevity as the life of buildings to reduce maintenance costs



Easy to install: Easy to cut and shaped with standard oodworking tools

COLOUR CHART



ACO-01



ACO-02



ACO-03



ACO-04



ACO-05



ACO-06



ACO-07



ACO-08



ACO-09



ACO-10



ACO-11



ACO-12



ACO-13



ACO-14

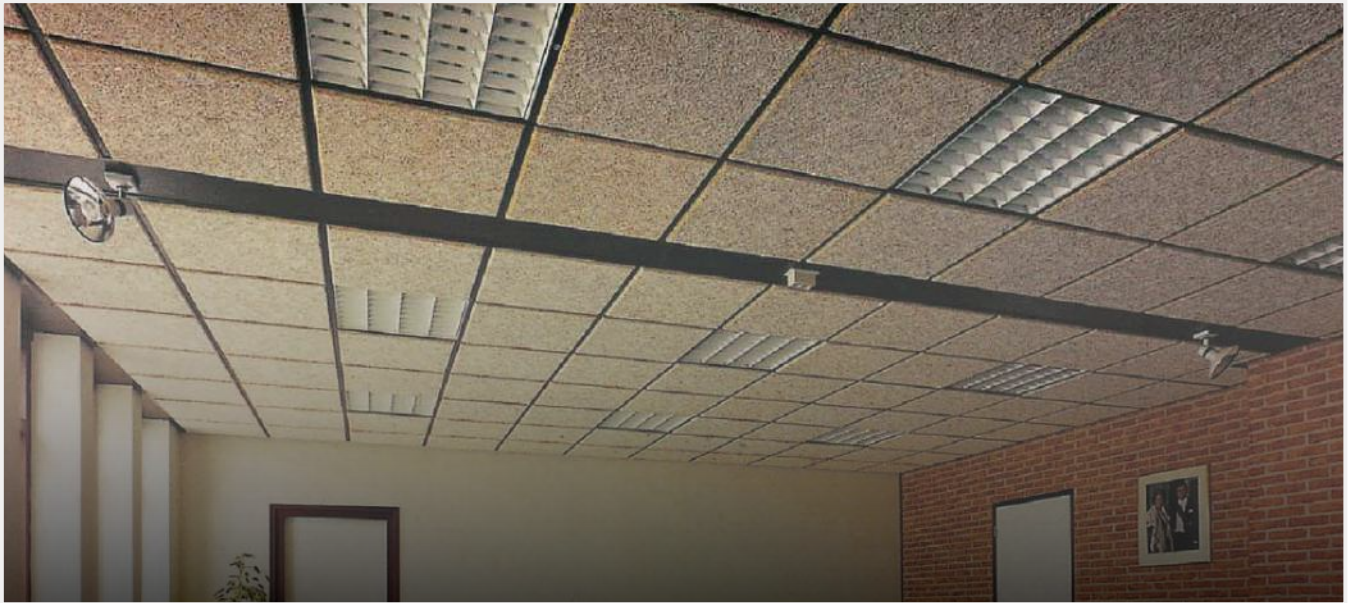

3D ART POLYESTER FIBER ACOUSTIC PANEL

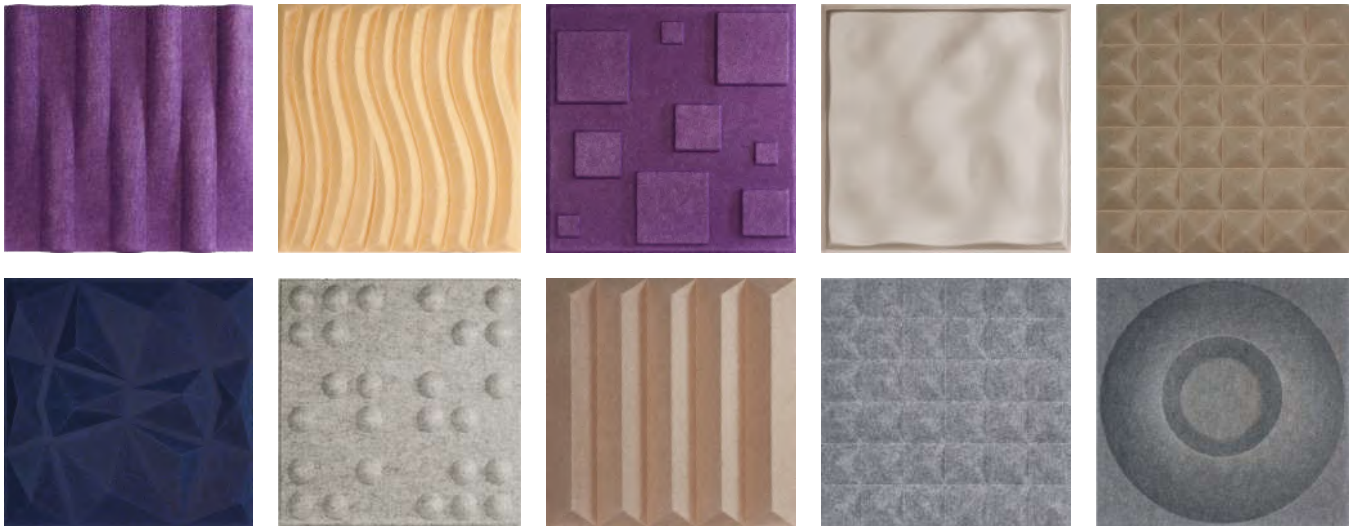

PRODUCT INTRODUCTION

This series of products has modern curves, geometric shapes and smooth edges, which is the product of the designers combination of natural laws and modern aesthetics. The 3D design has its own cavity, which has a more significant effect on low-frequency processing than the flat design, and the concave and convex parts can fully diffuse the excess sound rays, which can achieve full-frequency sound absorption and diffusion, making the sound of the whole place clearer and fullness; let acoustics and modern decorative aesthetics better blend together.

SPECIFICATIONS

Product Specifications	Length: 500mm Width: 500mm Thickness: 20mm/25mm/48mm/53 mm (size can be customized)
Advantages	light weight, strong decoration, good sound absorption performance, environmental protection & high-quality products.
Applicable Place	Office Space, Club house, Sports Hall, Public Area
Finish	Many colors choice
Material Consumption	Refer to Acoustic Design

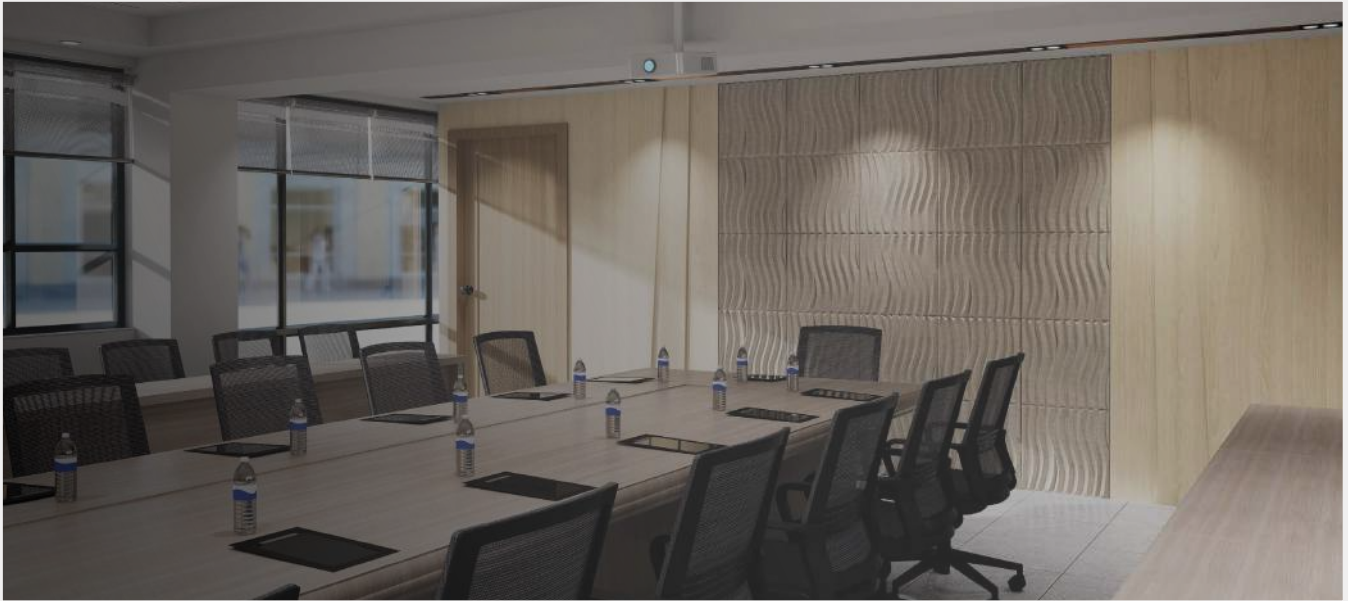

POLYESTER FIBER ACOUSTIC PANEL

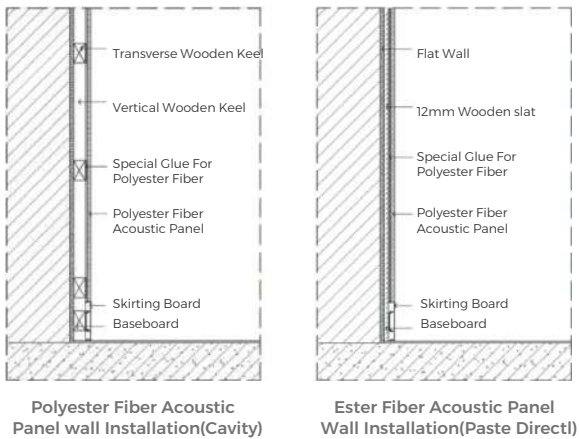

PRODUCT INTRODUCTION

ACO polyester fiber acoustic panel with high density, environmental protection, fire-retardant, wide frequency sound absorption, strong decoration, simple construction, easy cutting, no dust pollution and other properties, many color and decorative shape choices, can well meet customers acoustic and decoration requirements. The highest fire resistance grade B1, the highest environmental protection grade E1.

SPECIFICATIONS

Installation Accessories	Light steel keel, 9mm plywood batten, gun nails, nail free glue
Material Consumption	Refer to acoustic design
Substrate	100% polyester fiber
Corner Processing	Chamfering
Density	160-4400 gsm
Color	A variety of colors for customers to choose.
Size	W1200/1220*L2400/2440*T9/12 OR 15/18/20/24/48mm, customized

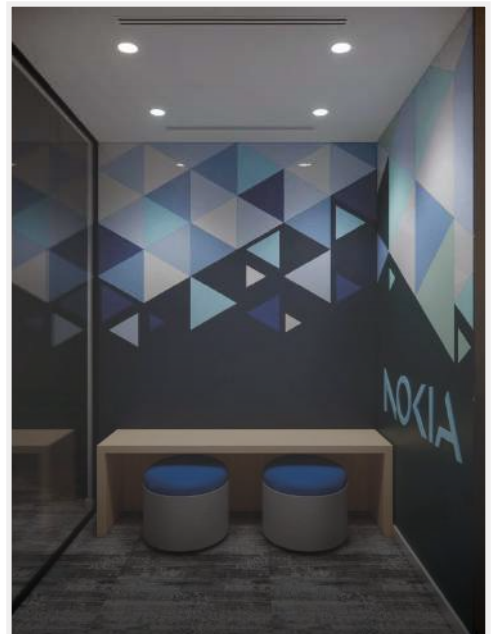
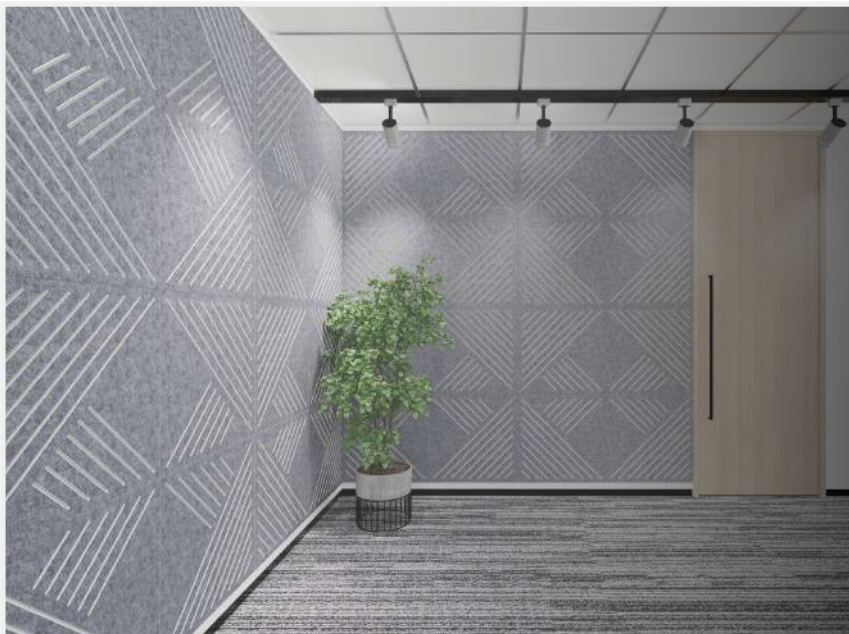
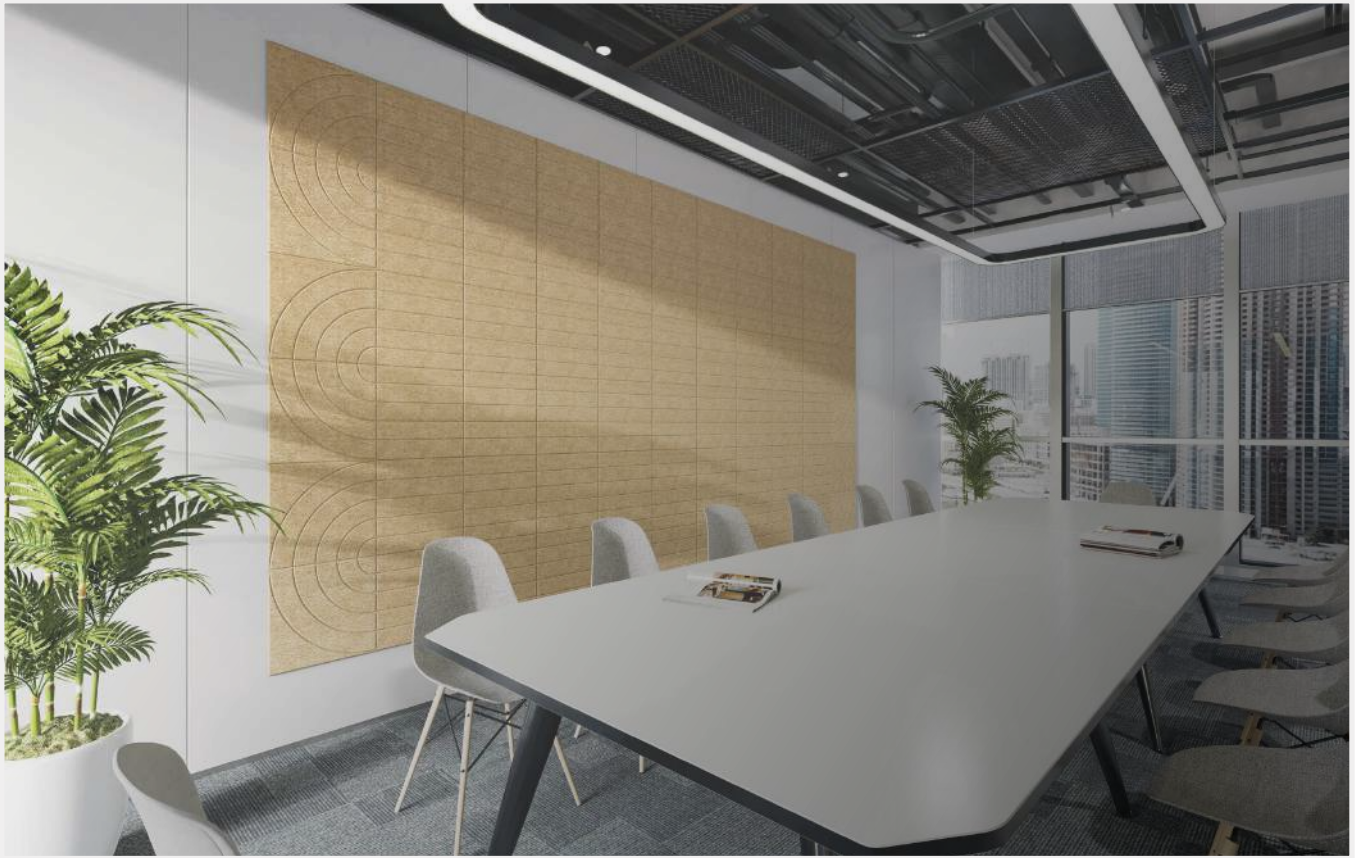



INSTALL METHOD

01. Array

Array the panel as per design drawing in construction place.

02. Cut

Either mechanical or hand cutting is fine.
Pls adopt hard guiding rule or export art knife.

03. Chamer

Array the panel as per design drawing in construction place.

04. Fix

Glue Is Common Use In The Construction, Such As Spay-Glue, White Glue, Hot Melt Adhesive And Glass Cement. Different Base Use Different Glue, You Can Fix It Directly On Plain Concrete Wall. Spay The Glue In Single-Side. Also, Laying-Install Is Recommended.

COLOUR CHART

					
ACO2601 Light Yellow	ACO26022 Orange Yellow	ACO2603 Tangerine	ACO2604 White	ACO2605 Beige	ACO2606 Dark Camel
					
ACO2608 Red Coffee	ACO2610 Silver Gray	ACO2611 Water Ash	ACO2612 Moonlight Gray	ACO2613 Fruit Green	ACO2614 Emerald Green
					
ACO2616 Dark Blue	ACO2617 Big Red	ACO2618 Purple Red	ACO2619 Violet	ACO2621 Light Sky Blue	ACO2622 Sky Blue
					
ACO26233 Police Blue	ACO2625 African Gray	ACO2626 Sesame Black	ACO2627 Black	ACO2605 Beige	ACO2629 Brown
					
ACO2630 Dark Brown	ACO2633 Deep Sky Blue	ACO2634 Dark Green	ACO2635 Sky Blue	ACO2636 Darkk Silver Gray	ACO2637 Lake Blue
					
ACO2638 Smoked Gray	ACO2639 Agate Gray	ACO640 Turquoise Green	ACO2641 Nile Blue	ACO2642 Elegant Blue	ACO2643 Kiwi Green

POLYESTER FIBER ACOUSTIC CEILING BAFFLE

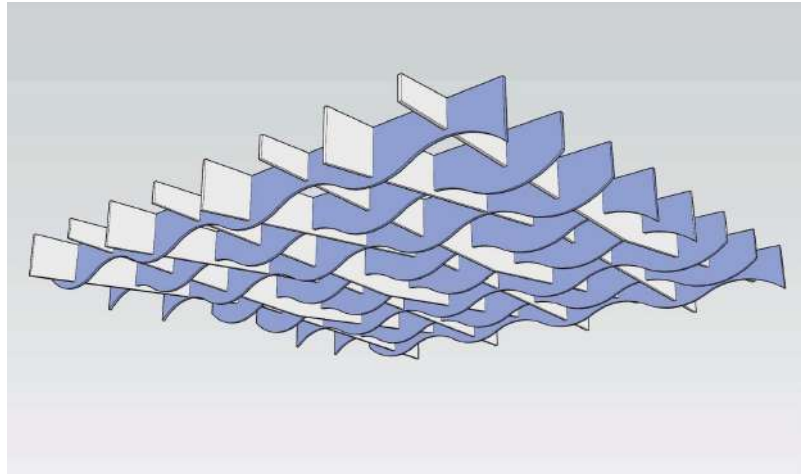

PRODUCT INTRODUCTION

Polyester fiber acoustic panel is made of 100% polyester fiber, hot press to cotton shape. The holes rate is more than 90%. It has good sound absorption performance in middle and high frequency. The polyester fiber acoustic panel is high density, eco-friendly, fire-resistant, easy to install and cut, no dust, various finish color and finish choices, can satisfy all customer's acoustic and decorative requirement.

FEATURES

Hotel, office, hospital, library, cinema, theater, concert hall, stadium, conference hall, factory, machine room, residential building, etc

SPECIFICATIONS

Base Materials	100% polyester fiber
Edge	Square, small bevel
Density	1350-4400g/m ²
Color	See color chat
Models	Square, Rectangle, Round, Hexagon,Wavy, Customized
Common Size	W12/18/18*H150/180/200*L1200/2400mm or Customized diameter:600mm
Tolerance	W±1mm, L±2mm, T±0.2mm



U SHAPE POLYESTER FIBER ACOUSTIC BAFFLES

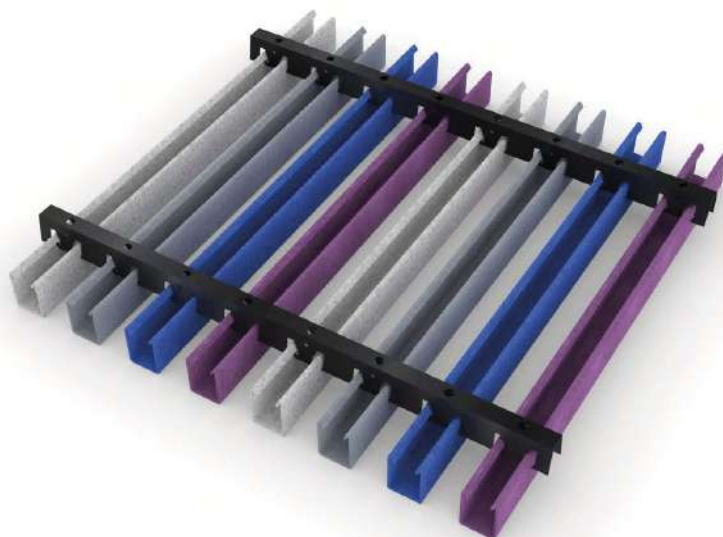

PRODUCT INTRODUCTION

U Shape Polyester Fiber Acoustic Baffles is made of 100% polyester fiber hot press to cotton shape. The holes rate is more than 90%. It has good sound absorption performance in middle and high frequency. The polyester fiber acoustic panel is high density, eco-friendly, fire-resistant, easy to install and cut, no dust, various finish color and finish choices, can satisfy all customer's acoustic and decorative requirement.

FEATURES

Hotel, office, hospital, library, cinema, theater, concert hall, stadium, conference hall, factory, machine room, residential building, etc

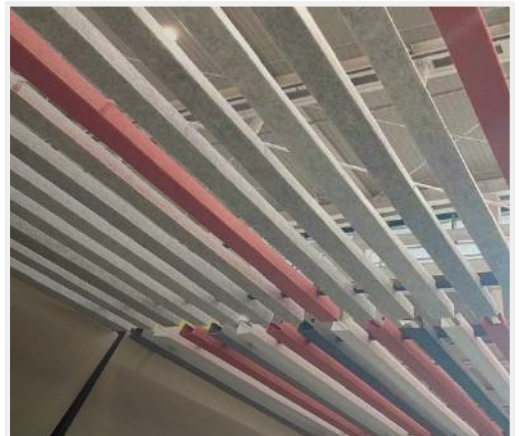

SPECIFICATIONS

Base Materials	100% polyester fiber
Density	1350-4400g/m ²
Color	See color chat
Models	Square, Rectangle, or Customized
Common Size	W40*L2400*H55mm; W40*L2400*H80mm; W 40*L2400*H200mm or customized
Tolerance	W±1mm, L±2mm, T±0.2mm



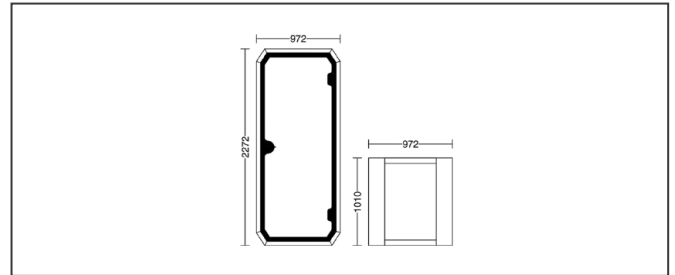

SILENCE BOOTH

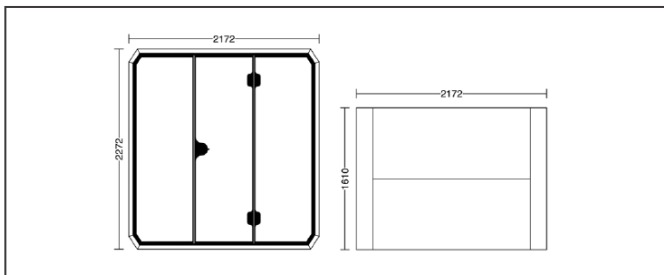

Seating Capacity	
Model	S
External Size	1010*972*2272mm
Internal Size	900*840*2140mm
Color Selection	
Application Scenario	Phone Booth/Solo Office/Saxophone



Seating Capacity	
Model	L
External Size	1610*2172*2272mm
Internal Size	1500*2040*2140mm
Color Selection	
Application Scenario	Chatting Room/Office/Recording Studio/Piano Training



SILENCE BOOTH

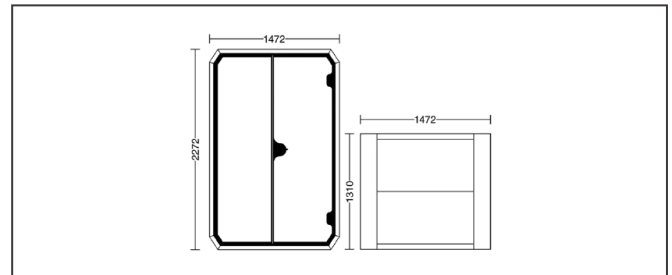

Seating Capacity	
Model	M
External Size	1310*1472*2272mm
Internal Size	1200*1340*2140mm
Color Selection	
Application Scenario	Phone Booth/Solo Office/Saxophone

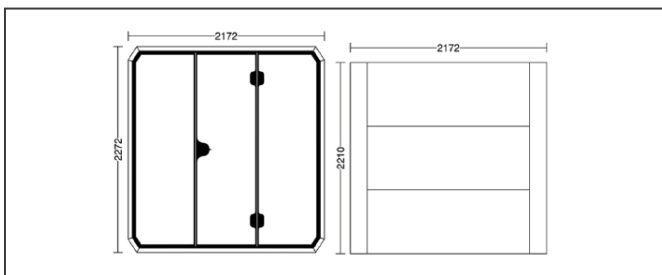

Seating Capacity	
Model	XL
External Size	2210*2172*2272mm
Internal Size	2100*2040*2140mm
Color Selection	
Application Scenario	Chatting Room/Office/Recording Studio/Piano Training



SILENCE BOOTH



PHONE BOOTH PRIVATE SPAD

In open-plan office environment, a private and soundproof phone booth is indispensable, but this problem has not been solved.

Imagine in the communication with customers, whether your background noise may be the bad experience to the customers?

Are you worried that your phone call may affect your colleagues?



MEETING POD TEAMWORK SPACE

There's only one conference room in most of companies, which can not meet the requirements of two meetings at the same time. Most of the time, a 2-6 persons group meeting only requires a small space for internal meetings and negotiating with customers. Our Silence Booth can perfectly solve this demand and fully improve the efficiency of the meetings.

MOVABLE PARTITION

• 65 SERIES

PRODUCT INTRODUCTION

65 series partiton can be divided into 360 degree turn whole direction single flim or single direction double films.

The top adopts 65 type pathway or hanging wheel,could divide up space flexibly in all-direction and multi-angles.

Screen borders are Processed and made by 6063T6 aluminium alloy materials which Chlorinated surface SNAdblasting is the highest grade material in our industry.

And can be pushed to anywhere.Slide show steady and smooth transformation of space diversity.For a high degree 2m-4.5m.the largest rail loading is 250kg/m.

Widely used in hotels, guesthouses, medium – sized meeting room, multi-purpose conference room.

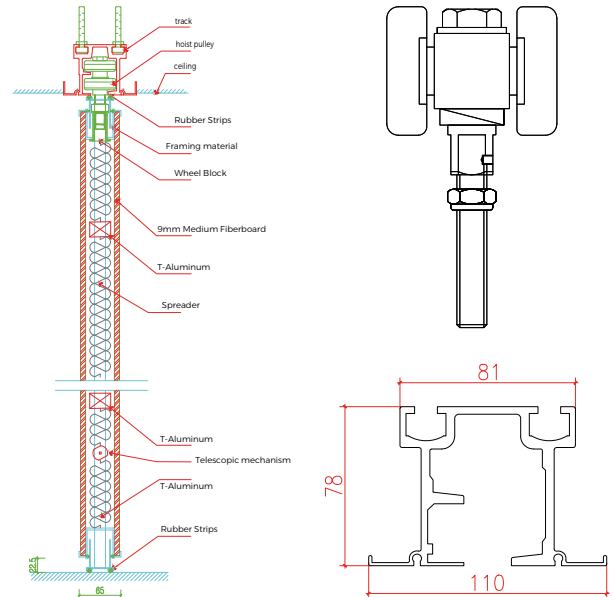

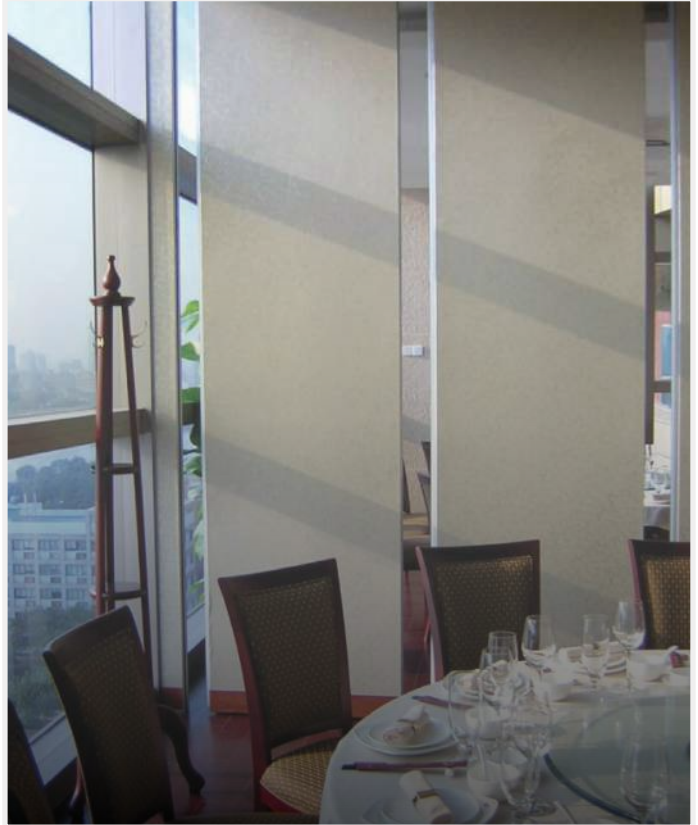

• 85 SERIES

PRODUCT INTRODUCTION

85 Series partition can be divided into 360 degree turn whole direction single film or single direction double films.

The top adopts 85 type pathway or hanging wheel, could divide up space flexibly in all-direction and multi-angles.

Screen borders are Processed and made by 6063T6 aluminium alloy materials which Chlorinated surface SNAdblasting is the highest grade material in our industry.

And can be pushed to anywhere. Slide show steady and smooth transformation of space diversity. For a high degree 4m-7.5m. the largest rail loading is 480kg/m.

Widely used in hotels, guesthouses, medium – sized meeting room, multi – purpose conference room.

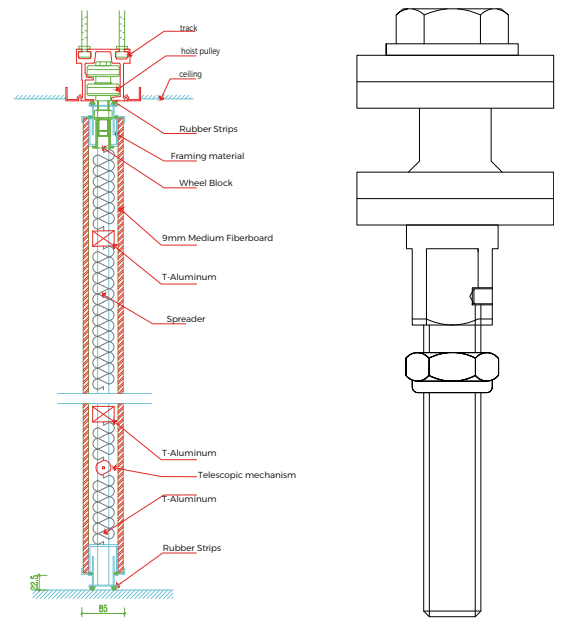

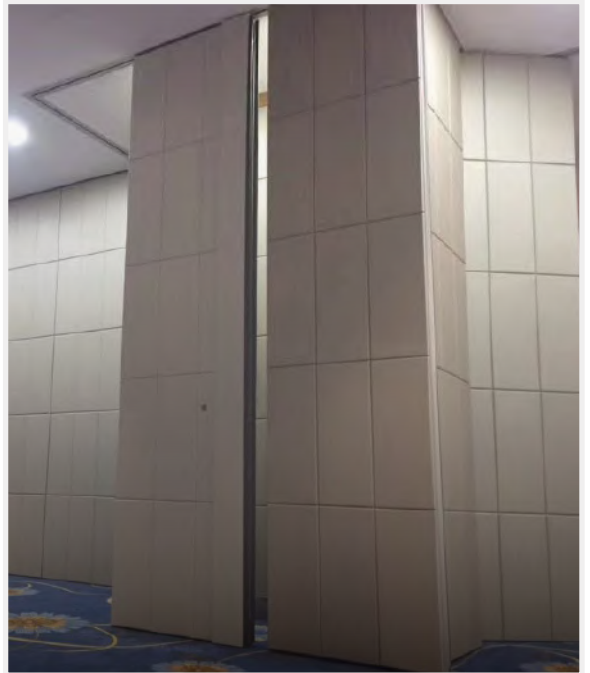
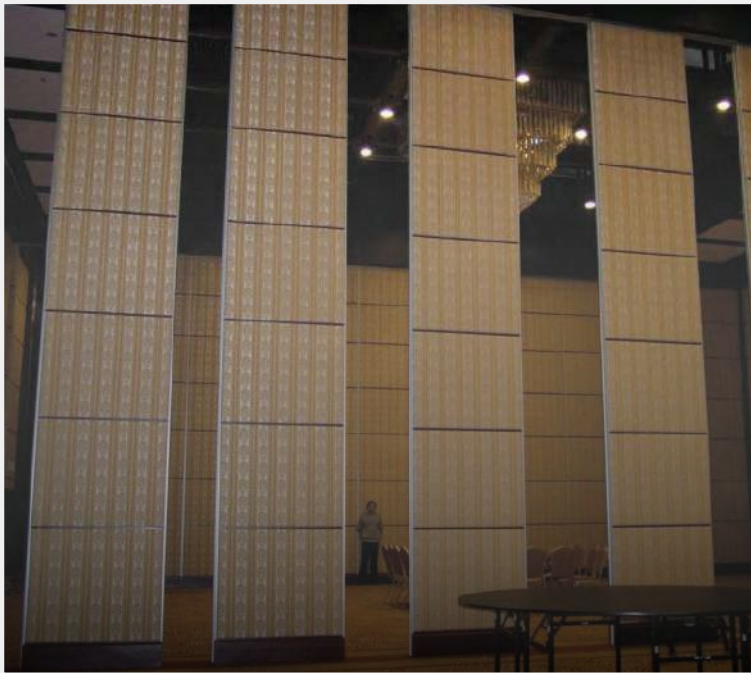

WOODEN DIFFUSER **WD SERIES**



DEFECT OF PLANE REFLECTION

If someone enjoy the music in a rectangular hall, the sound he heard is harsh and stiff. It is sound frequency dyeing.

PRODUCT FEATURE

Wooden diffuser is a anomalous plane design which can bring diffusion while refectation. The sound is sonorous And reverberation is from different direction to the audience. It can greatly improve the acoustic environment in the hall.

PRINCIPLE OF DIFFUSION

Acoustic diffusion series is base on QRD diffusion principle QRD diffusion is Quadratic residue theory. The diffusion boards are composed of steps of different depths based on calculations as per the quadratic residue theory The Sound energy enters steps and is then gradually released at different time. The result is that the peaks and valleys are smoother, forming a more balanced acoustic environment. The diffusion boards are used not only on ceiling but also on the side walls and the walls behind loudspeakers and behind the listening positions. The more the diffusion materials, the more can people feel that the sense of space and the natural and graceful effect of high frequencies in the music places. The details of music can also be shown well.

ACO-D1

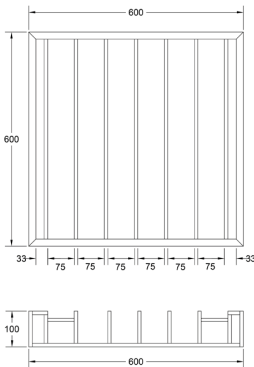

ACO-D2

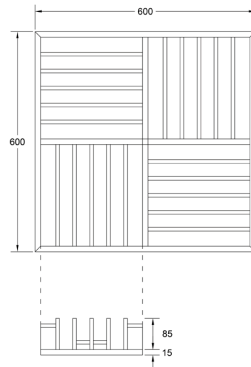

ACO-D3

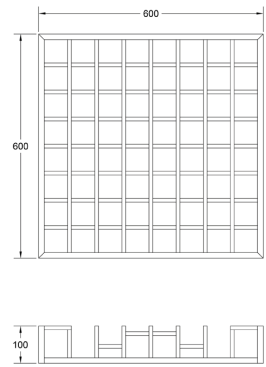

Frrequency	125	160	200	250	315	400	500	630	800	1000	1250	1600	2000	2500	3150	4000
ACO-D1 Diffusion Coefficient	0.01	0.01	0.00	0.00	0.02	0.08	0.18	0.25	0.36	0.40	0.41	0.35	0.43	0.58	0.55	0.48
ACO-D2 Diffusion Coefficient	0.01	0.01	0.02	0.00	0.10	0.10	0.38	0.40	0.49	0.30	.041	0.62	0.57	0.58	0.57	0.38
ACO-D3 Diffusion Coefficient	0.02	0.05	0.01	0.01	0.00	0.00	0.01	0.02	0.08	0.41	0.30	0.49	0.43	0.43	0.43	0.68

SPECIFICATIONS

Name	QRD Solid Wood Diffuser
Base Matenals	Rubber Solid Wood / MDF
Finish	PU Painting / Melamine / Veneer
Mode	ACO-D1 ACO-D2 ACO-D3
Features	D1 D2 D3 diffuser scattered the incidence sound to avoid echo and stationary wave. It make sound field uniform distribution and improve sound environment. Diffusion frequency range D1(500HZ-2000HZ) D2(615HZ-1229HZ) D3(675Hz-2150HZ)
Ecn-friendly	Non-formaldehyde
Common Size	W600mm * L600/1200/1800mm * T100mm

ACO-D5

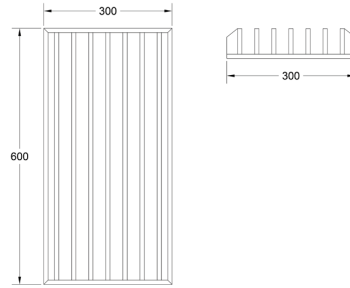

ACO-D6

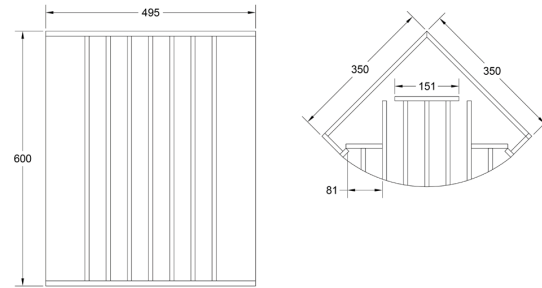
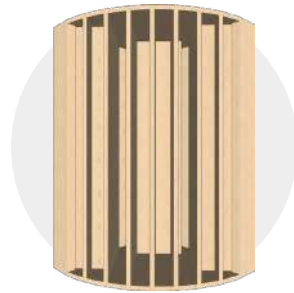

Frequency	125	160	200	250	315	400	500	630	800	1000	1250	1600	2000	2500	3150	4000
ACO Diffusion Coefficient	0.01	0.01	0.00	0.00	0.00	0.09	0.41	0.39	0.41	0.50	0.33	0.39	0.62	0.52	0.52	0.34
Frsequency	1000	1250	1600	2000	2500	3150	4000	5000	6300	8000	10000	12500	16000	20000		
ACO-D5 Diffusion Coefficient	0.01	0.30	0.43	0.60	0.54	0.60	0.72	0.63	0.52	0.52	0.45	0.40	0.42	0.43		
ACO-D6 Sound Absorption Coefficient	0.00	0.33	0.40	0.55	0.68	0.60	0.55	0.58	0.52	0.52	0.48	0.47	0.42	0.30		

SPECIFICATIONS

Name	D5 QRD Diffuser / D6 Bass Trap Diffuser
Base Materials	Rubber Solid Wood / MDF
Finish	PU Painting / Melamine / Veneer
Mode	ACO-D5 ACO-D6
Features	D5 diffuser can restore sound space feeling and greatly improve sound quality in hall. It can raise sound environment clear satiation and three-dimensional. D6 diffuser is a good case for comer stationary wave solutions It mix low frequency sound absorption and diffusion together. D6 diffuser not only solve sound in comer but also make full use of the spacial place, increasing 3db sound energy in small space. It greatly Improve acoustic environment.
Ecn-friendly	Non-formaldehyde
Common Size	D5: W 300mm * L 1800/2400mm * T 70mm D6: W 540mm * L 1200/1800/2400mm * T 158mm

ACO-D8

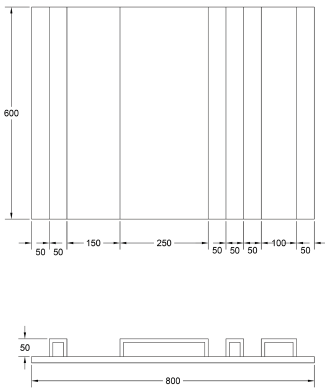

ACO-D9

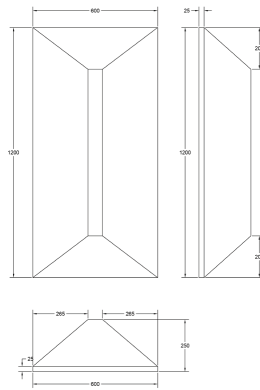

ACO-D10

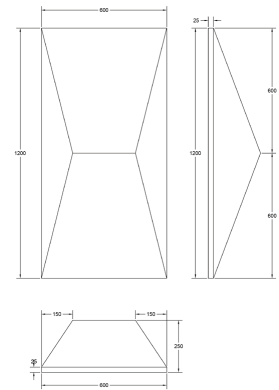

SPECIFICATIONS

Name	Diffuser
Base Materials	Rubber Solid / Fire-resistant MDF
Finish	Pu Painting / Melamine / Veneer / HPL
Mode	ACO-D8 / D9 / D10 / D11 / D12 / D13 / D14
Features	MLS diffuser has superior diffusion performance,scattered the incidence sound to avoid echo and stationary wave.It makes sound field uniform distribution and improves sound environment. Diffusion frequency range:500Hz-4000Hz
Ecn-friendly	Non - formaldehyde
Common Size	As Per Customer Request

ACO-D11

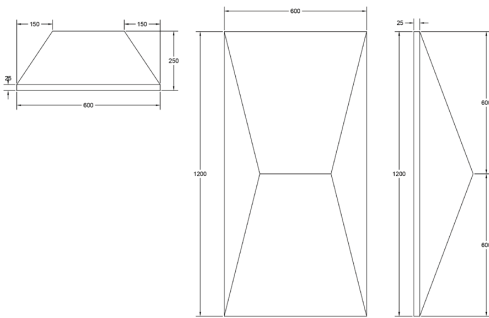

ACO-D12

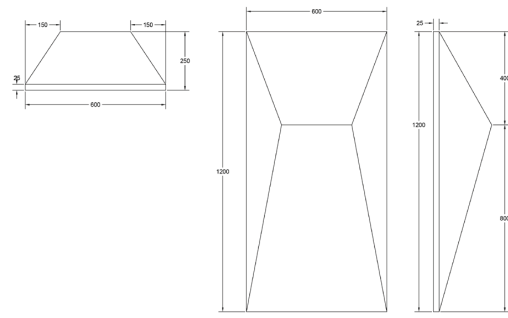

ACO-D13

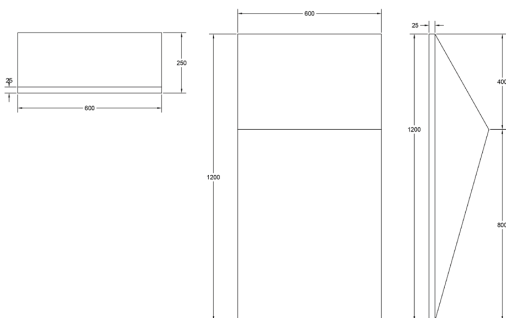

ACO-D14

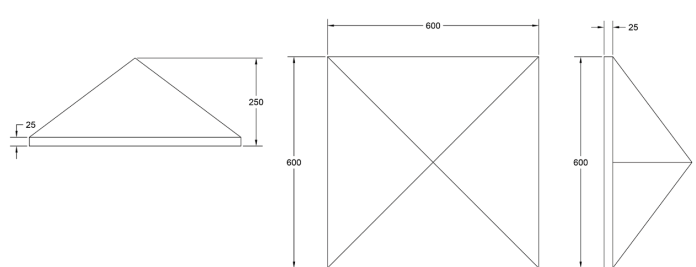

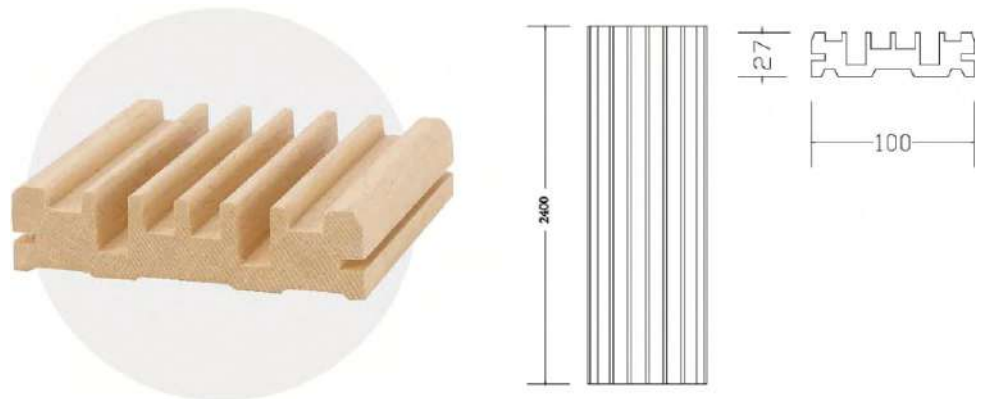

ACO-D16

SPECIFICATIONS

Name	Solid Wood Acoustic Diffuser
Base Matenals	Solid wood
Finish	PU painting
Mode	ACO-D16
Features	ACO-D16 diffuser can restore sound space feeling and greatly improve sound quality in hall. It can raise sound environment clear satiation and three-dimensional.
Ecn-friendly	Non-formaldehyde
Common Size	W100mm * L 2400mm * T 27mm
Application	Concert Hall, Family Theater, Hifi Studio

DIFFUSION ACOUSTIC PANEL DA SERIES



DA-1



DA-2

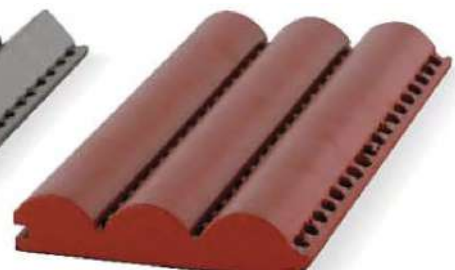

DA-3

Frsequency	100	125	160	200	250	315	400	500	630	800	1000	1250	1600	2000	2500	3150	4000
Cvlinder ACO-D6 Diffusion Coefficient	0.15	0.30	0.42	0.59	0.72	0.83	0.95	0.90	0.85	0.66	0.58	0.50	0.45	0.42	0.37	0.39	1.19
Triangle ACO-D6 Diffusion Coefficient	0.19	0.33	0.42	0.62	0.75	0.85	0.89	0.82	0.75	0.64	0.55	0.52	0.42	0.42	0.39	0.39	0.40

Frsequency	1000	1250	1600	2000	2500	3150	4000	5000	6300	8000	10000	12500	16000	20000
Cvlinder ACO-D6 Diffusion Coefficient	0.01	0.00	0.00	0.00	0.02	0.10	0.13	0.30	0.42	0.30	0.45	0.52	0.45	0.39
Triangle ACO-D6 Diffusion Coefficient	0.01	0.01	0.00	0.01	0.02	0.08	0.06	0.25	0.53	0.57	0.43	0.32	0.38	0.45

SPECIFICATIONS

Name	Diffusion Acoustic panel
Base Matenals	MDF
Finish	PU Painting / PVC
Mode	DA-1 / DA-2 / DA-3
Features	Triangle or Cylinder Groove in Surface, perforated in Back with Fire-resistant Acoustic Tissue, painting Finish.
Ecn-friendly	Formaldehyde Class reach E1
Common Size	W 128mm * L 2440mm * T 21/25mm
Application	TV, Theater, Opera Hall, Concert Hall, Conference Center, Stadium Mall Hotel Restaurant.



SOUND **INSULATION**

Noise is kind of sound which cause human upset or endangers human health in strong volume. Noise is one of most significant problems in the fast urban development process. Series of environmental noise control standards has been issued by China public.

Sound insulation and sound absorption are two different concepts. In structure, the sound insulating materials are dense and heavy. While the sound absorbing materials are porous and light. The main function of sound insulating materials are sound insulation but low sound absorption. But the main function of sound absorbing materials are sound absorption but low sound insulation rate.

The sound propagation is divided into air-borne and structure-borne sound propagation. Sound insulation is a way to cut off the airborne sound propagation. Vibration insulation is the control of structure-borne sound propagation caused by vibration through the media. So, Sound insulation and ibration insulation will be treated separately.

There are three factors to generate and transmit the noise: Noise source, propagation path and receiver. Most adults can hear the noise with frequency range from 100HZ to 4000HZ. The frequency of conversation and common noise in the buildings is basically 125HZ to 4000HZ. The wall sound reduction STC refers to the sound insulation capability of wall to the noise within the range of 125 HZ TO 4000HZ..

DECIBEL

Decibel (DB) is a unit used for expressing the sound relative intensity. Physically, the defined reference acoustic pressure($P_0=2 \times 10^{-5}$ pa) corresponds to ODB. If the noise pressure is P, the noise decibel is equal to $20 \log(P/P_0)$ /So decibel is a designated unit. As the same as earthquake magnitude unit expressing the earthquake intensity. the collapsing force of earthquake at a scale of 6 is generally low, but the earthquake at a scale of 7 may cause a greater disaster.a

SOUND REDUCTION INDEX

The sound insulation function of materials is the capability to reduce the noise intensity. If the sound of one room is 75DB, the sound transmitted to the adjacent room through the wall will be reduced to 40DB. So the sound insulation function of the wall is 35DB.

SOUND INSULATION BOARD IB SERIES

COMPOUND DAMPING SOUND INSULATION BOARD IB01/IB02

Compound damping and sound insulation board is made of inorganic materials with different densities on both sides (6mm and 9mm white inorganic board in surface and back or 6mm black inorganic in surface and 9mm white in back), is sandwiched with high polymer damping adhesive in core. High pressure composite molding forms the constrained damping structure, changes the resonant frequency of the original materials and greatly increases the airborne sound insulation index and structure sound insulation index.

APPLICATION

Residence, hotel, leisure club, KTV and other places which need to increase wall and ceiling sound reduction index.



COMPOSITE CORK DAMPING AND SOUND INSULATION BOARD IB05

Timber damping and sound insulation board adopts 9mm fire-resistant plywood and in surface and 6mm high density inorganic board on the bottom surface, the high polymer damping adhesive is sandwiched, and the three materials with different properties are molded compositely under high pressure.

Features: It is green, eco-friendly, easy to cut and install. The timber layer surface provides a rich later forming condition.



SPECIFICATIONS

Model	Surface Density	Weight of Single Pcs	Common Size	Area of Single Pcs
IB01	18.5	55	1220*2440*16	2.97
IB02	19.8	59	1220*2240*16	2.97
IB05	14.4	43	1220*2440*18	2.97

DEADENING FELT DF SERIES

PRODUCT INTRODUCTION

Deadening Felt is a kind of newly sound insulation product, which made from macromolecule material, metal powder and other accessory ingredient. Deadening Felt is widely used at Modern building industry, home furnishing factory work shops, machine rooms, air compressor space, meeting room, multi function hall, KTV room office and car which place need sound insulation.



SPECIFICATIONS

Name	Deadening Felt
Eoo-friendly	Formaldehyde Class reach E1.
Fre-reactant	Burning safely, the flame Put out after removing
Coammon Size	W 1200mm * L 5000/10000mm * T 1.2/2.0/3.0mm
Toierance	W ±2mm * L ±2mm * T ±0.5mm

INSTALL METHOD

1. Directly rigid touching among panels, keels and the wall is not allowed. The louching point for the wall maybe putted damping insulation felt as spacer.
2. There are always lights, exhaust fan, Smoke Sensor and air dust in the ceiling or on the lop of the wall. Sound insulation will be considered in advance for the devices and the pipes.
3. The damping insulation felt should cover all the space. Specially the gap between panels and felte, dont overloup.
4. Reserve places for weak electric wires connector and consider sound insulation in advance.
5. For high request for sound insulation places, the whole sound insulation solutions will be necessary.

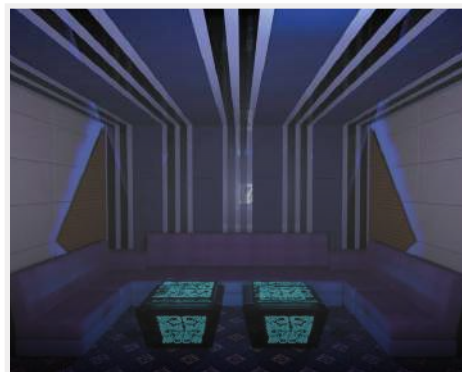

SOUND AND VIBRATION INSULATION MAT SV SERIES

PRODUCT INTRODUCTION

Sound and vibration mat is made of high density polyethylene foam after nanometer technology. The mat has obvious effect on the improvement of the floor impact sound. The materials wont observably increase the floor and building structure loading as the light weight. It is kind of eco-friendly, economical and durable product. It can be used more than 70 years.

FEATURES

Moisture-proof, waterproof, mouldproof , easy to install, easy to cut, etc.

APPLICATION

KTV, disco, gym, home theater, engine room, upscale residential district and some places have a noise source nearby.

INSTALL METHOD

1. Keep the ground clean and smooth, and cut the product according the required size.
2. Made the absorption mat on the floor, and its laying position should align at the joint of skirting line, also taped up the joints.
3. Avoid the leakage and the seam paving between the mat and the ground.
4. After install the mat, the cement, finished tiles and wood floor should be immediately covered onto the mat.



VIBRATION ABSORBER VA SERIES

CEILING VIBRATION ABSORBER /WALL VIBRATION ABSORBER

Ceiling vibration absorber is made of 100% original high polymer vibrationdamping adhesive, the aging resistance time and the damping coefficient are five times that of the refurbishing adhesive, thereby ensuring the permanencyand safety of vibration damping and sound insulation effect in the aspect ofhardware quality. It is an effective way to cut off the structure-borne sound transmission of the suspended ceiling and the original base building ceiling. Wall vibration absorber is suitable for installing and fixing the wallreinforced sound insulation structure layer of form the sound insulation layer between the sound wave irradiation surface and the original base wall.

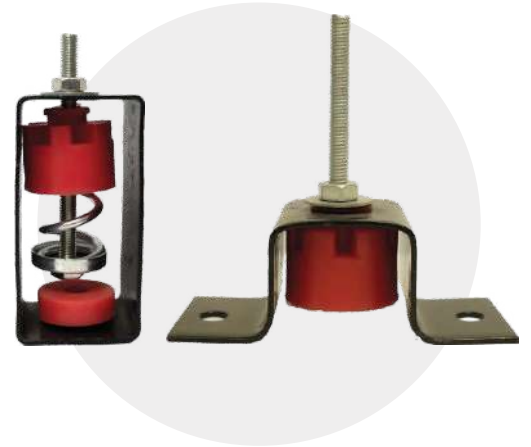

SMALLPOX SHOCK ABSORBER/WALL SHOCK ABSORBER

SPECIFICATIONS

Name	Ceiling Vibration Absorber / Wall Vibration Absorber
Comon Size	Ceiling: W 50mm * L 100mm * T 50mm Wall: W 50mm * L 110mm * T 50mm
Bearing Weight	Ceiling: 25KG-35KG Wall: 25KG-50KG
Efective Frequency Range	80Hz-150Hz
Install Method	Expansions Screw Fix
Application	Bar. KTV room, Music studio, etc.

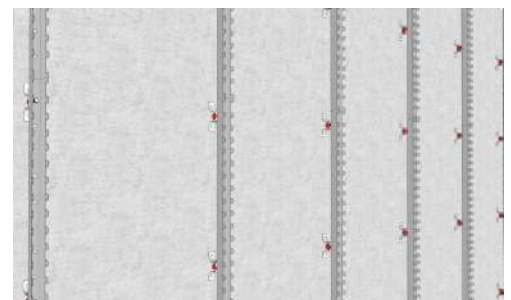
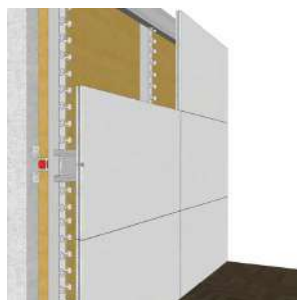
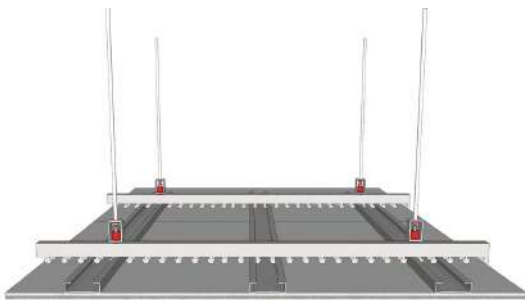

SOUND INSULATION VIBRATION KEEL

Sound insulation vibration keel adopt natural rubber materials and light steel keel. Nature rubber is a soft link with wall and light steel keel. It cut off the sound bridge and have good reduction for low and high frequency vibration. The empty space install method for keel, have obvious sound insulation and vibration effect in wide frequency. The damping rubber also has sound insulation and vibration effect for wall body vibration in low frequency. The simple structure and less space, low natural vibration frequency, good vibration effect keel. which is an idea device for wall body.



SPECIFICATIONS

Keel	Width in top: 35mm, width in bottom: 67mm, height: 25mm.
Rubber	W 25.5mm * L 92mm * H 22mm

GROUND VIBRATION ABSORBER

Ground vibration absorber adopts the short travel ultra-strong metal damping spring, and the high polymer vibration damping rubber block is adhered to the botom plate of the vibration absorber to orm the dual-material wideband vibralion absorbing structure. The application of ground vibralion absorber for constructing the floating floor can effectively cut off the impact of vibralion radiation layer on the original base layer, thereby improving the low frequency vibration and impact sound insulation properties,



COMMON SIZE

W 100mm * L 100mm T 95mm

APPLICATION

Bar, KTV room, Music studio, etc.

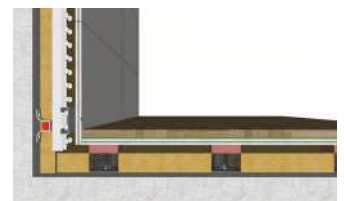



SOUND INSULATION **DOOR ID SERIES**

As the economic developing, the demand of life quality for people is more and more exquisite.

Professional sound insulation door is wide used in recording studio five-star hotel, high end villa and office building.

Professional sound insulation door adopt several different materials board and damping vibration insulation treatment base on Mass law and acoustic principle.

It use unbalance air layer acoustic structure design, filed with high density fiberglass.

The door has obvious sound insulation performance in middle and high frequency (250-5000HZ).

We have three type doors for different customer request as belows: Metal wood composite sound insulation door, Metal sound insulation door, wood sound insulation door.

METAL WOOD COMPOSITE SOUND INSULATION DOOR



PRODUCT INTRODUCTION

Metal and wood composite sound insulation door adopt galvanized steel plain board inorganic board, wood board, damping layer and gas seal five different materials molded compositely under high pressure with magnetic control rubber seal strip. The finish is natural veneer finish and various finish for choice.

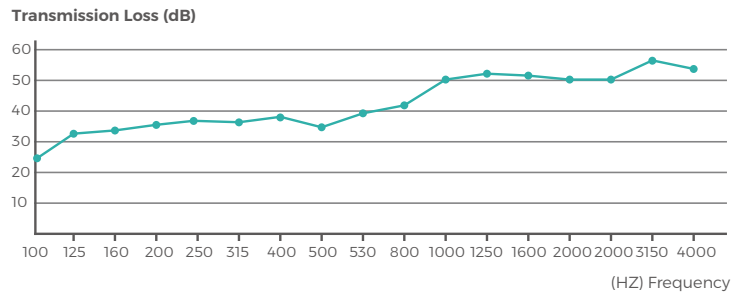

SPECIFICATIONS

Name	Metal Wood Composite Sound Insulation Door
Model	ID01
Finish	Natural Veneer Finish
Common Size	Single leaf: W 860mm * H 2050mm * T 70mm Double leaf: W 1500mm * H 2100mm * T 70mm
Sound Rerduction Index	Single: STC40-50DB Double: STC35-45DB
Threshold	Optional
Opening Directhon	Optional
Lock	Standard or Optional
Application	Hotel, Home, Audition Room, Music Room, Entertainment Venues, Conference Hall, Home Theater

METAL SOUND INSULATION DOOR



PRODUCT INTRODUCTION

Metal sound insulation door is made of galvanized steel plain sheet, fled with damping sound insulation wool and any other insulation materials, with magnetic control rubber Seal strip. It include design with threshold and without threshold. Without threshold design adopt liftable bottom seal strip, reduce the sound leak.

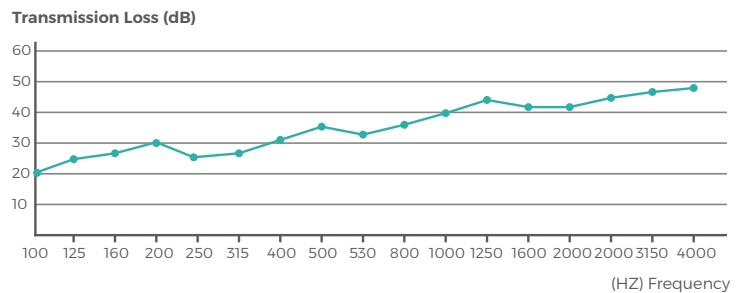

SPECIFICATIONS

Name	Metal Sound Insulation Door
Model	ID02
Finish	Baking Finish, Wood Grain Transfer Printing Finish
Common Size	Single leaf: W 860mm * H 2050mm * T 70mm Double leaf: W 1500mm * H 2100mm * T 70mm
Sound Rextduktion Index	Single: stc40-45db Double: stc35-40db
Threshold	Optional
Opening Directhon	Optional
Lock	Standard or Optional
Application	Hotel, Home, Audition Room, Music Room, Entertainment Venues, Conference Hall, Senior Office

WOOD SOUND INSULATION DOOR

PRODUCT INTRODUCTION

wood sound insulation is made of solid wood, fled with damping sound insulation wool and using magnetic rubber seal strip.

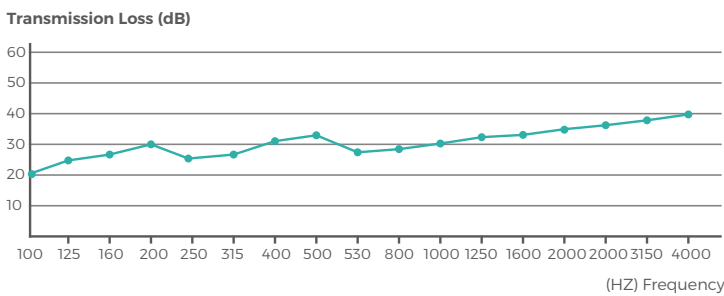

SPECIFICATIONS

Name	Wood Sound Insulation Door
Model	ID03
Finish	Natural Veneer Finish
Common Size	Single leaf: W 860mm * H 2050mm * T 50mm Double leaf: W 1500mm * H 2100mm * T 50mm
Sound Rextrduction Index	Single: STC35-40DB Double: STC30-35DB
Threshold	Optional
Opening Directhon	Optional
Lock	Standard or Optional
Application	Hotel, Home, Audition Room, Music Room, Entertainment Venues, conference Hall, Senior Office

MASS LOADED VINYL

MLV



Introduction:

ACOUSTIEG flexible mass loaded vinyl (MLV) is a soundproofing felt having a certain flexibility of rubber. With polymer materials as the main raw material, it's mainly used with MgO or gypsum board for wall insulation and ceiling insulation, and also applies to pipes, machinery noise and vibration damping devices. The sound insulation mass loaded vinyl can reduce the transmission energy of the incidence sound source and keep the room quiet.

Application:

KTV, disco, gym, home theater, engine room, upscale residential district, etc

SPECIFICATIONS

Name	MLV, Rubber Vibration Damping Felt
Material	Rubber, damping mastic
Structure	Black + white + black; Black
Color	Black
Thickness	1.2/2/3mm
Size	1*5m/1*10m/customized
Package	It is wrapped in nylon bag outside, if you have special requirements, you can customize the packaging

Detail Pictures:



Advantage Details:

- Fine Eyelet Pattern on Front



- Material Toughness and Softness



- High Quality Non-woven Fabric is Attached to the Back



- Waterproof and High Temperature Resistant



Water and Moisture Proof



Fire Resistance to High Temperature

Small Stature **High Weight**

The higher the density, the heavier the weight and the better the sound insulation



Specifications (mm)	Length Unit (m)	Unit of Width (m)	Unit of Area (m ²)	Unit of Weight (m ²)
1.2mm	10m	1m	10m ²	2.4kg/m ²
2.0mm	10m	1m	10m ²	4kg/m ²
3.0mm	5m	1m	5m ²	6kg/m ²

Acoustics Data:

Sound Reduction Data Curve Graph

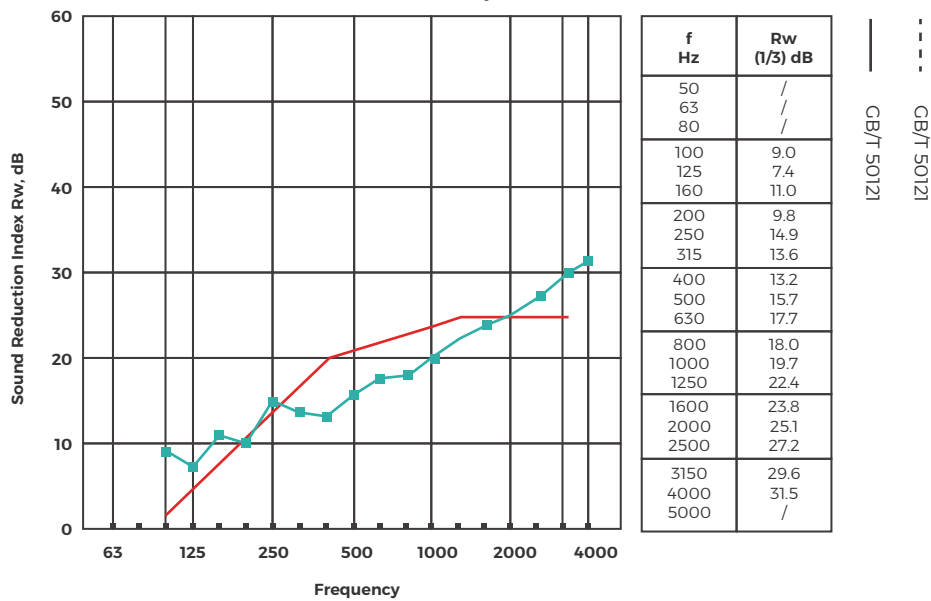

Installation:

Easy to Install

Just Tow Steps

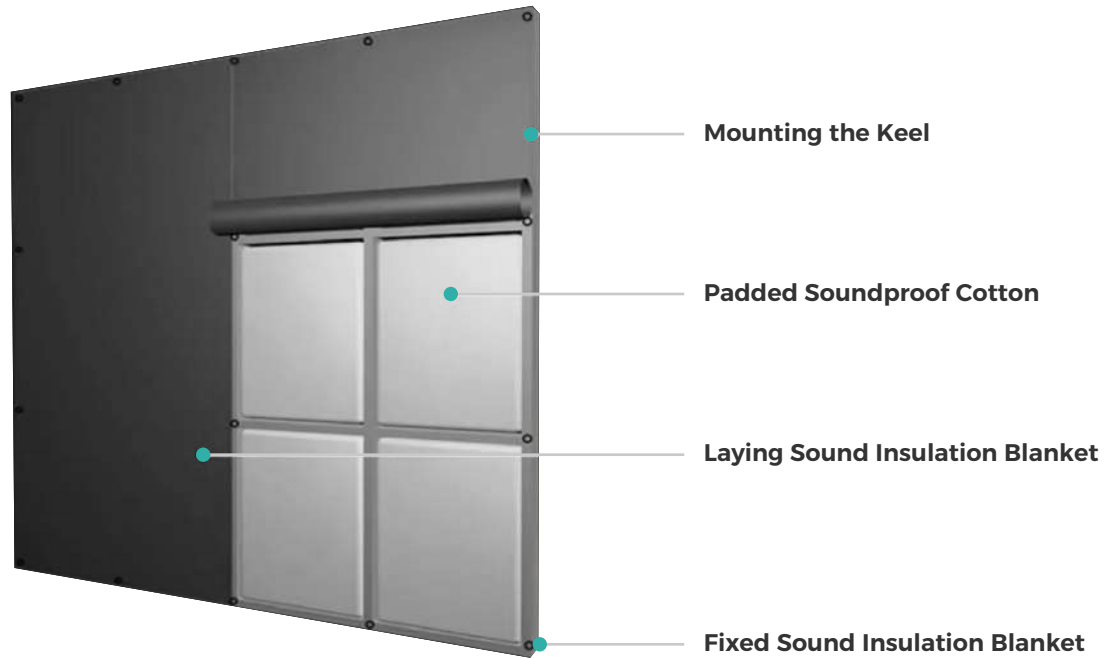

Factory:



Cases:

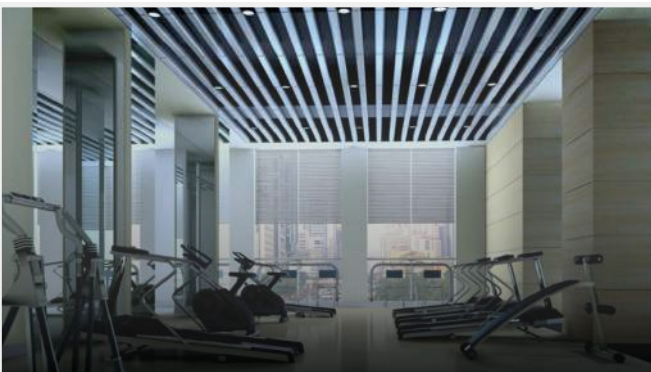
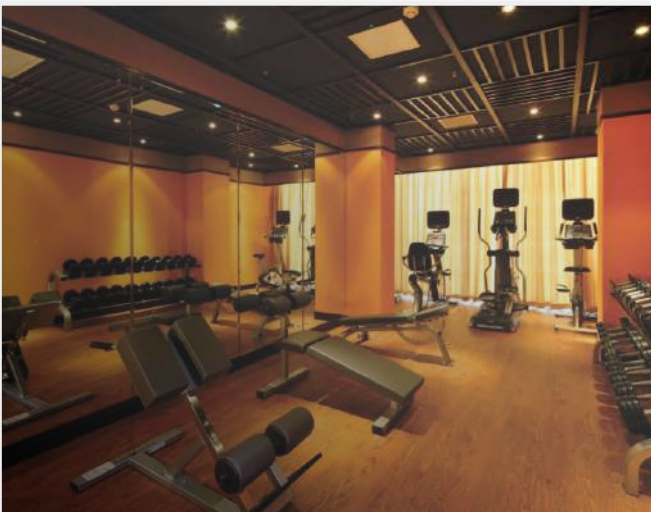

ACOUSTIC OFFICE FURNITURE

PRODUCT INTRODUCTION

Designed with solid color throughout, ACO acoustic furniture have always been the first choice for designers and architects around the world with both functional, sustainable, decorative and great unwanted reverberation reduction.

The free standing variable acoustic screen is used in the face-to-face position, providing strong sound absorption, separation and bass control, and expands personal space as well.

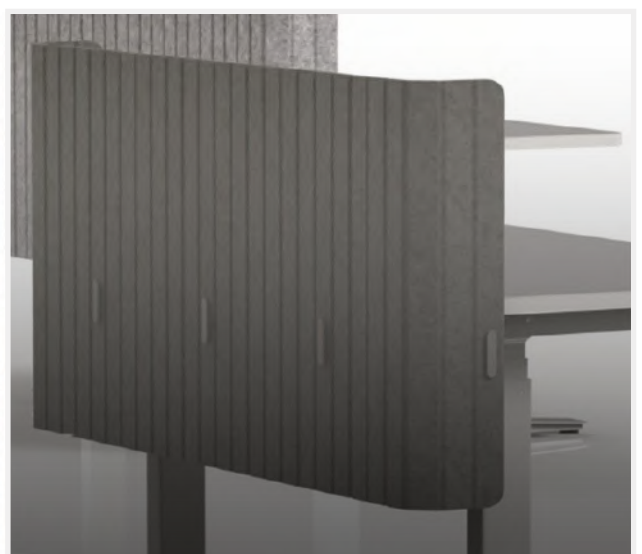
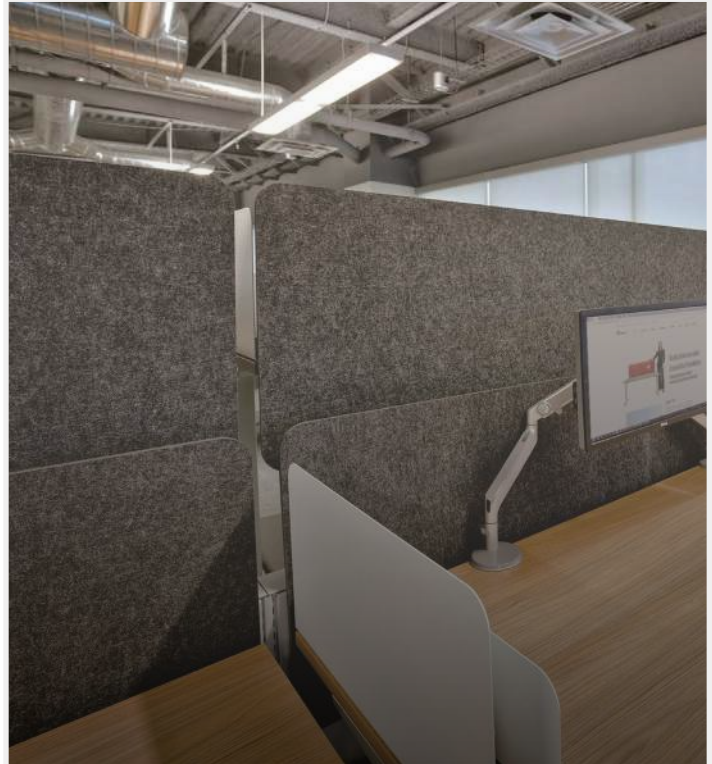

ACOUSTIC FURNITURE

EMBOSSED DESK DIVIDER

01

Big Acopot

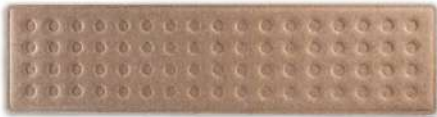

Size

920*300*14mm
1180*300*14mm

Finishes

ACO Standard Panel
or ACO felt

Mounting

Desk Mounted with
clips

Small Acopot



Size

1030*330*13mm
800*330*13mm
1030*500*13mm

Finishes

ACO Standard Panel
or ACO felt

Mounting

Desk Mounted with
clips

Acohung



Size

1180*580*16mm

Finishes

ACO Standard Panel
or ACO felt

Mounting

Desk Mounted with
hangers

Acolot



Size

580*340*16mm
1180*340*16mm
1380*340*16mm

Finishes

ACO Standard Panel
or ACO felt

Mounting

Desk Mounted with
clips

Acoprotrusion



Size

1400*560*18mm
1160*450*18mm
1160*500*18mm
1160*550*18mm

Finishes

ACO Standard Panel
or ACO felt

Mounting

Desk Mounted with
clips or hangers

Acoround



Size

1100*300*15mm
800*300*15mm

Finishes

ACO Standard Panel
or ACO felt

Mounting

Desk Mounted with
clips or hangers

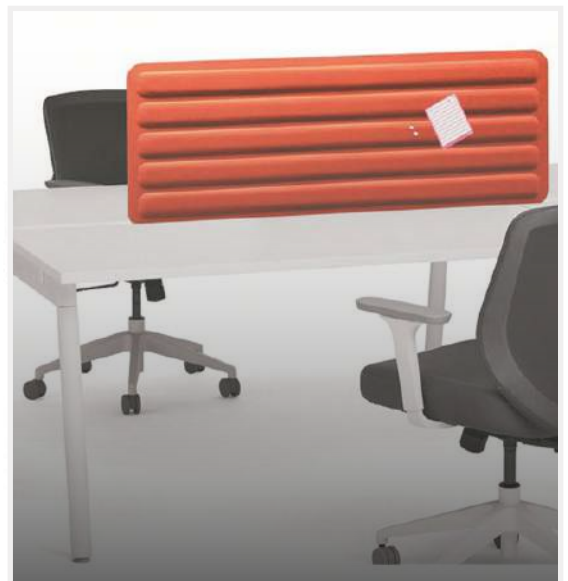
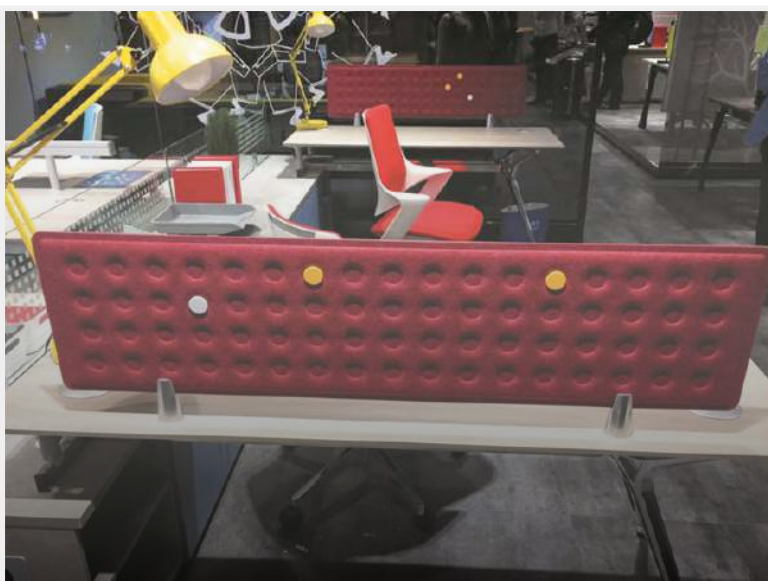

ACOUSTIC FURNITURE

ENGRAVING DESK DIVIDER

02

Acopanel



Size

2400*400*12mm
1200*400*12mm
1200*600*12mm
or Customized

Finishes

ACO Standard Panel

Mounting

Desk Mounted with clips or hangers

Acocarved



Size

2400*400*12mm
1200*400*12mm
1160*500*12mm
or Customized

Finishes

ACO Standard Panel
or ACO felt

Mounting

Desk Mounted with clips or hangers

Acofold



Size

2400*400*12mm
2000*400*12mm
1800*400*12mm
or Customized

Finishes

ACO Standard Panel

Mounting

Desk Mounted with clips or hangers

Acoinsert



Size

2400*400*12mm
2000*400*12mm
1800*400*12mm
or Customized

Finishes

ACO Standard Panel

Mounting

Insert directly on the desk

Acowave



Size

2400*600*12mm
2000*600*12mm
or Customized

Finishes

ACO Standard Panel

Mounting

Desk Mounted with hangers

DESK DIVIDER MOUNTINGS

Clip



Hanger



Color

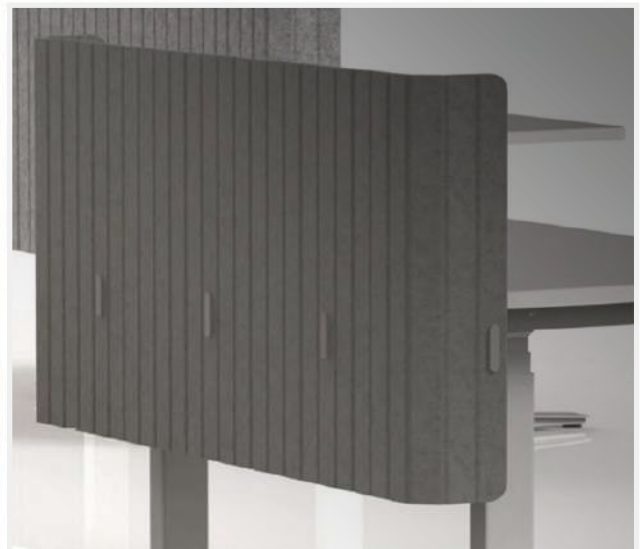

ACOUSTIC FURNITURE WORKSTATION

03

1160H Workstation



Size

- 1160*450*18mm
- 1160*500*18mm
- 1160*550*18mm
- 1160*200(R)*18mm

Finishes

- ACO Standard Panel
- or ACO felt

Mounting

- Wooden connection
- and screws



1400H Workstation



Size

- 1400*560*18mm
- 1400*560*18mm

Finishes

- ACO Standard Panel
- or ACO felt

Mounting

- Wooden connection
- and screws

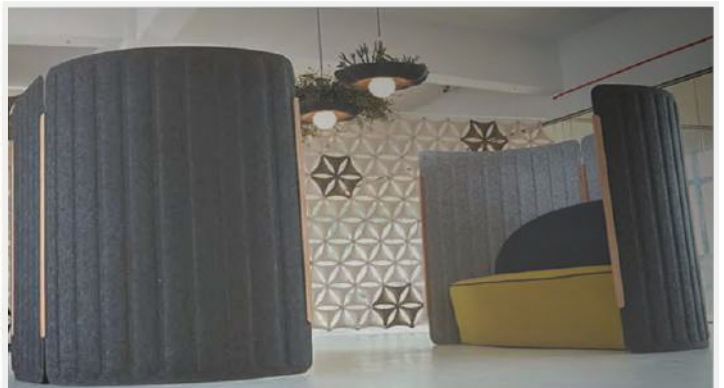

NOISE BARRIER



PRODUCT INTRODUCTION

Noise barrier is designed to solve noise control applications where both sound absorption and sound blocking must be increased. Industrial applications include enclosures, machinery cover linings, and additions to existing walls Or barriers. Architectural applications include crosstalk barriers, room dividers, ceiling barriers, and pipe and duct wrap.

SPECIFICATIONS

Name	Noise Barrier
Finish Material	PVC Tarpaulin & Fabric
Inner Material	Sound Absorption + Absorption Material
Color	Green, Grey, Black, Blue and more
Thickness	15/18 mm
Size	2400*1000 / 2400*1000mm or customized
Weight	7kgs/Sqm
Absorption Face Design	Rhombus, Vertical Line, Square
Absorption Coefficient	17-27dB

PRODUCT FEATURES

ACO-1 Sound Absorption & Block Noise Barrier (Stand Type)

FEATURE

- **Sound Block** (STC range of 16-24DB)
- **Sound Absorption** (NRC range of 0.55-0.80)
- **Fire Rate** (AS/NZS 1530.3:1999)
- **Weight: 5.5lb -15.40lb/sqm**
- **Waterproof / Fireproof**
- **UV Resistance**
- **Easy Installation**



SOUND ABSORPTION

Frequency (Hz)	100	125	160	200	250	315	400	500	630	800	1K	1.25K	1.6K	2K	2.5K	3.15K	4K	5K	NRC
Absorption Coefficient (α)	0.02	0.10	0.10	0.16	0.36	0.46	0.55	0.65	0.67	0.69	0.70	0.64	0.59	0.55	0.50	0.46	0.40	0.39	0.55

NOISE REDUCTION

Frequency (Hz)	125	160	200	250	315	400	500	630	800	1K	1.25K	1.6K	2K	2.5K	3.15K	4K	STC
Transmission Loss (dB)	14.9	14.7	15.3	17.5	19.1	19.6	20.5	23.2	24.2	26.5	28.6	31.4	33.8	34.5	34.8	34.5	26

ACO-2 Sound Absorption & Block Noise Barrier (High Performance Type)

FEATURE

- **Sound Block** (STC 27 DB)
- **Sound Absorption** (NRC 0.80)
- **Fire Rate** (AS/NZS 1530.3:1999)
- **Weight: 16.94lb -38.30lb/sqm**
- **Waterproof / Fireproof**
- **UV Resistance**
- **Easy Installation**



SOUND ABSORPTION

Frequency (Hz)	100	125	160	200	250	315	400	500	630	800	1K	1.25K	1.6K	2K	2.5K	3.15K	4K	5K	NRC
Absorption Coefficient (α)	0.22	0.26	0.34	0.37	0.60	0.60	0.78	0.85	0.96	0.90	0.98	0.99	0.96	0.91	0.83	0.84	0.85	0.81	0.80

NOISE REDUCTION

Frequency (Hz)	100	125	160	200	250	315	400	500	630	800	1K	1.25K	1.6K	2K	2.5K	3.15K	4K	5K	STC
Absorption Coefficient (α)	15.2	20	15.5	17.2	19.8	19.9	22.5	24.3	25.0	26.5	27.5	27.9	28.0	29.0	30.8	30.5	30.9	32.8	27

LY-3 Sound Block Noise Barrier

FEATURE

- **Sound Block** (STC 26 DB)
- **Fire Rate** (AS/NZS 1530.3:1999)
- **Weight: 12lb -160lb/sqm**
- **Waterproof / Fireproof**
- **UV Resistance**
- **Easy Installation**



LY-2 Sound Absorption & Block Noise Barrier (High Performance Type)

FEATURE

- **Sound Block** (STC 24 DB)
- **Sound Absorption** (NRC 0.80)
- **Fire Rate** (AS/NZS 1530.3:1999)
- **Weight: 11.20 lb - 15.40lb/sqm**
- **Waterproof & Fireproof**
- **Easy Installation**



ABSORPTION FACE DESIGN



Square



Vertical Line



Rhombus

ACOUSTIC PERFORMANCE

Sound Insulation Test Report

Test Date	05.09.2017	Temp	27°C
Sound Source Room Volume	162m ³	RH	67%
Receiving Room Volume	90m ³		
Specimen Size	3.6m x 2.8m		

Frequency (Hz)	Sound Transmission Class R1	Sound Transmission Class R2	Sound Transmission Class R
125	14.4	15.4	14.9
160	14.6	14.8	14.7
200	15.8	14.9	15.3
250	18.2	16.8	17.5
315	18.8	19.4	19.1
400	19.3	20.0	19.6
500	20.6	20.5	20.5
630	23.2	23.2	23.2
800	24.3	24.1	24.2
1000	26.4	26.6	26.5
1250	28.8	28.4	28.6
1600	31.5	31.2	31.4
2000	33.5	34.0	33.8
2500	34.5	34.4	34.5
3150	35.0	34.6	34.8
4000	34.6	34.3	34.5

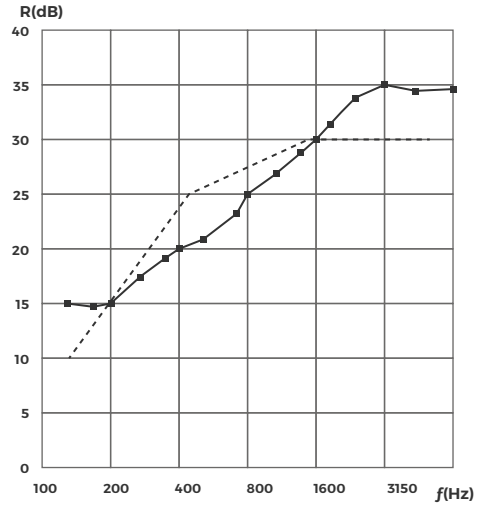

Reference Contour (Solid Line) Fitted to Transmission Loss Data (Symbols+Line)
Test result: According to E413, Sound Transmission Class of this Specimen is 26 dB.

Sound Absorption Test Report

Test Date	01.09.2017	Temp	29°C
Measurement Room Volume	162m ³	RH	67%
Specimen Size	7.2m ²		

Frequency (Hz)	Adjusted Decay Rate of the Empty Room	Sound Absorption of the Empty Room	Adjusted Decay Rate of the Room with the Specimen	Sound Absorption of the Room with the Specimen	Sound Absorption
100	17.80	7.64	18.23	7.82	0.02
125	12.19	5.23	14.67	6.29	0.10
160	13.58	5.82	16.06	6.89	0.10
200	17.81	7.64	21.72	9.31	0.16
250	16.62	7.13	25.56	10.96	0.36
315	17.39	7.46	28.73	12.32	0.46
400	18.67	8.01	32.12	13.78	0.55
500	17.88	7.67	33.92	14.55	0.65
630	16.91	7.25	33.45	14.35	0.67
800	16.20	6.95	33.05	14.17	0.69
1000	15.51	6.65	32.60	13.98	0.70
1250	15.36	6.59	31.07	13.32	0.64
1600	15.72	6.74	30.12	12.92	0.59
2000	16.39	7.03	29.75	12.76	0.55
2500	17.68	7.58	29.87	12.81	0.50
3150	19.14	8.21	30.49	13.08	0.46
4000	21.89	9.39	31.74	13.61	0.40
5000	25.07	10.75	34.71	14.89	0.39

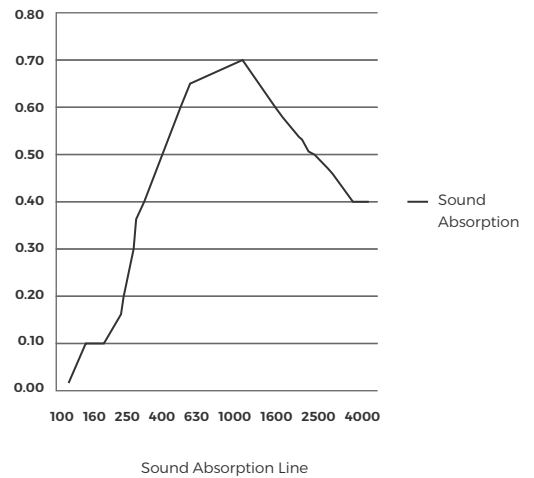

APPLICATION

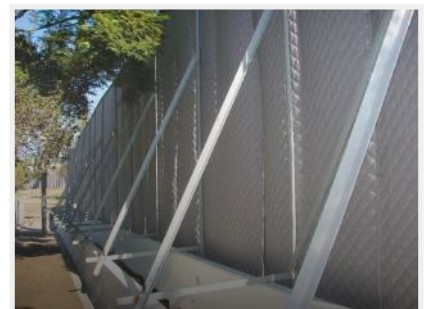

ACOUSTIEG LOCATIONS

With branches located in Riyadh and Dammam, we proudly serve the Kingdom of Saudi Arabia, Visit us at our locations in Dammam or Riyadh to experience top-quality service and results.

- **Riyadh**
- **Dammam**



ACOUSTIEG CERTIFICATES

- Previous Mega Projects Approval

Royal Commission for Alula

Doc No:	ALLAIRINF7011-TD-B500-AP-000-PQD-AR-000023
Rev.:	01
Date:	01 October 2024
Page:	1 of 2



Document Transmittal Form

Part 1 – Issue / Distribute

Employer:	Royal Commission for Alula
Project Management Consultant:	SEA PMCM
Site Supervision Consultant:	Saudi Consulting Services Co.
Contractor:	Technical Development for Contracting Company
Project Title:	Expansion of Existing Terminal T1 at AlUla Airport.
Contract no.:	CW13242 / PR15137
Aconex Project no.:	ALLAIRINF7011

Document Title/Description

1. Prequalification for Acoustic (Acoustieg)

Compliance Statement: We certify that the Document (s) Transmitted herewith has been reviewed in detail and in accordance with the Contract Drawing and Specifications except as otherwise stated here above.

Document Type (Tick Applicable)

<input checked="" type="checkbox"/> Prequalification Submittal	<input type="checkbox"/> Insurance and Bond	<input type="checkbox"/> Proposal	<input type="checkbox"/> Manual	<input type="checkbox"/> Register	<input type="checkbox"/> Guidelines
<input type="checkbox"/> Photos, Images & Videos	<input type="checkbox"/> Organization Chart	<input type="checkbox"/> Presentation	<input type="checkbox"/> Report	<input type="checkbox"/> List	<input type="checkbox"/> Others (please specify)
<input type="checkbox"/> Personnel Approval Form	<input type="checkbox"/> Calculation	<input type="checkbox"/> Permit	<input type="checkbox"/> Schedule	<input type="checkbox"/> Warranty	

Purpose of Issue For Review For Coordination For Information

Authorized by:

Name	Designation	Sign & Stamp	Remarks
Engr. Nabil Bahrouni	Project Manager		

Part 2 – Site Supervision Consultant Review Comments and Approval (If Required)

Review Comments (to be completed by the Site Supervision Consultant)

Name: _____ Date: _____

Signature: _____

A. Approved B. Approved with Comments C. Revise and Resubmit D. Rejected

Authorized by:

Name	Designation	Sign & Stamp	Remarks
			

Template No. ALULA0000-SEA-XX-AA-000-FM-PX-000006
Project Manager
Saudi Consulting



Page 1 of 2

Diriyah Gate Company

7/13/24, 10:17 AM Aconex

Vincent Pepe Final (WF-626308) DG-BUJ-104-Pre-Qualification for Acoustic - Acoustieg Company 9:53 AM
SCHIATTARELLA ASSOCIATI WORKFLOW TRANSMITTAL SCT-WTRAN-013082

Diriyah Gate Company Limited Phase 1
 8500 Prince Sultan Ibn Abdulaziz Al Shoh
 AD DIRIYAH 12572
 Riyadh
 4000 Saudi Arabia

SCHIATTARELLA ASSOCIATI

MAIL TYPE: **Workflow Transmittal** MAIL NUMBER: **SCT-WTRAN-013082** REFERENCE NUMBER: **SCT-WTRAN-013082**

Final (WF-626308) DG-BUJ-104-Pre-Qualification for Acoustic - Acoustieg Company

From: Vincent Pepe - Schiattarella Associati

To (2): Mr Mohammed Mahfooz - MOHAMMED M. ALRASHID TRADING & CONTRACTING COMPANY (MARCO) (+1 more...)

Cc (37): Mr Mark Davies - Currie & Brown (+36 more...)

Sent: Saturday, 13 July 2024 9:53:38 AM AST (GMT+03:00)

Status: N/A

▼ DOCUMENT ATTACHMENTS (1)

(0 selected)

File	Document No	Revision	Revision Date	Title	Status
	DG-BUJ-104-0000-MRC-PQQ-PR-000051	00	07/07/2024	Pre-Qualification for Acoustic - Acoustieg Company	A- Approved

▼ ATTRIBUTES

Attribute 1: DG1/DG/BUJ/104-Diriyah Art Futures

▼ MESSAGE

Workflow Review History



The attached documents have completed the "DG-BUJ-104-Pre-Qualification for Acoustic - Acoustieg Company" workflow with the following results:

This transmittal was automatically generated

Doc No	Step	Participant	Review Outcome	Comments
(Empty table body)				

<https://ksa1.aconex.com/hub/index.html> 1/2

TBC Ministry of Education

PROJECT:	SCHOOLS INFRASTRUCTURE DEVELOPMENT PROGRAMME PUBLIC PRIVATE PARTNERSHIP WAVE 2	Transmittal No.:	BEC-EPC-ALL-PRO-ARC- MSC-000073
		Rev. No.:	01
		Date:	07-Nov-23
The Procurer:	The Contractor:	The Building Contractors (BC):	
			

TRANSMITTAL	DOC <input type="checkbox"/>	MAT <input checked="" type="checkbox"/>	PRQ <input type="checkbox"/>	DD <input type="checkbox"/>	SD <input type="checkbox"/>
--------------------	------------------------------	---	------------------------------	-----------------------------	-----------------------------



Recipient: : EPC (The Building Contractor)
 Attention: : Eng. Ahmed Hassan
 Subject : Material submittal for Wood wool acoustic for MPH
 Manufacturer and Supplier: ACOUSTIEG

WE ARE SENDING	SUBMITTED FOR	ACTION TAKEN
<input type="checkbox"/> Drawings	<input checked="" type="checkbox"/> Approval	<input type="checkbox"/> Approved as Submitted
<input type="checkbox"/> Specifications	<input type="checkbox"/> Action	<input type="checkbox"/> Approved with Comments
<input type="checkbox"/> Time Schedule	<input type="checkbox"/> As Requested	<input type="checkbox"/> Revise & Resubmit
<input checked="" type="checkbox"/> Report	<input type="checkbox"/> Review & Comment	<input type="checkbox"/> Rejected
<input type="checkbox"/> Change Order	<input type="checkbox"/> Information & Record	<input type="checkbox"/> Not Reviewed (Incomplete)
<input type="checkbox"/> Change Order Proposal		
<input checked="" type="checkbox"/> Others		

Discipline: Structural Architectural Mechanical Electrical General

No	DOC/ REF#	Description	Qty.
1	AS Attached	Material submittal for Wood wool acoustic for MPH	1 PDF File (139 Pages)

Remarks:
.....

<table style="width: 100%; border-collapse: collapse;"> <tr> <th colspan="2" style="text-align: center; border-bottom: 1px solid black;">Sender</th> </tr> <tr> <td style="width: 30%;">Issued By:</td> <td>BEC Contractor Eng. Nashaat Sanad</td> </tr> <tr> <td>Signature:</td> <td></td> </tr> <tr> <td>Date:</td> <td>07-Nov-23</td> </tr> </table>	Sender		Issued By:	BEC Contractor Eng. Nashaat Sanad	Signature:		Date:	07-Nov-23	<table style="width: 100%; border-collapse: collapse;"> <tr> <th colspan="2" style="text-align: center; border-bottom: 1px solid black;">Recipient</th> </tr> <tr> <td style="width: 30%;">Received By:</td> <td></td> </tr> <tr> <td>Signature:</td> <td></td> </tr> <tr> <td>Date:</td> <td></td> </tr> </table>	Recipient		Received By:		Signature:		Date:	
Sender																	
Issued By:	BEC Contractor Eng. Nashaat Sanad																
Signature:																	
Date:	07-Nov-23																
Recipient																	
Received By:																	
Signature:																	
Date:																	



WAVE II - Schools Project

Distribution Copy TBC W2C BC Other Specify

Royal Commission for Alula

10/10/2024, 08:28 Aconex

Bassam Abdullatif Final (WF-00240) Prequalification 7:16 AM
SEA PGMC WORKFLOW TRANSMITTAL SEAPGMC-WTRAN-000466



العينة الملكية لمحافظة العلا
Royal Commission for Alula

ALL-AIR-INF-17011
Existing Terminal Expansion T1



SEA
INFRASTRUCTURE PROGRAM &
CONSTRUCTION MGT.

MAIL TYPE
Workflow Transmittal

MAIL NUMBER
SEAPGMC-WTRAN-000466

REFERENCE NUMBER
SEAPGMC-WTRAN-000466

Final (WF-00240) Prequalification

From: Mr Bassam Abdullatif - SEA PjMC

To (12): Mr Hassan Ejaz Kiyani - SAUDCONSULT (+11 more...)

Cc (9): Mr Mohammed Afzaluddin - AtkinsRéalis Saudi Arabia (L11) (+8 more...)

Sent: Thursday, 10 October 2024 7:16:19 AM AST (GMT +03:00)

Status: N/A

DOCUMENT ATTACHMENTS (1)

File	Document No.	Revision	Revision Date	Title	Status
	ALLAIRINF7011-TD-BS00-AP-000-PQD-AR-000023	01	01/10/2024	Prequalification for Acoustic (Acoustieg)	B - Approved with Comments

ATTRIBUTES

Attribute 1: Architect

MESSAGE

Workflow Review History

The attached documents have completed the "Prequalification" workflow with the following results :

This document was automatically generated

Doc No	Step	Participant	Review Outcome	Comments
ALLAIRINF7011-TD-BS00-AP-000-PQD-AR-	SC technical review	A Mohamed Ahmed Fageir	B - Approved with Comments	Refer to CRS NO- ALLAIRINF7011-TD-

https://ksa1.aconex.com/hub/index.html?mainTarget=%2FViewCorrespondence%3FCorrespondence_ID%3D1381529568%26CORRESPONDENCE_... 1/2

Red Sea Global



MAIL TYPE
Workflow Transmittal

MAIL NUMBER
TRS03C05-WTRAN-013712

REFERENCE NUMBER
TRS03C05-WTRAN-013712

Final (WF-003597) Acoustic Spray Foam ACOUSTIEG

From Mr Ahmed Nagy - The Red Sea Development Company

To (10) Mr Sayed Shah - Bull Industrial Co
Mr Suresh Perumal - The Red Sea Development Company
Mr Mohamed Refaat - The Red Sea Development Company
Mr Mohammed Sahwan - The Red Sea Development Company
Mr Wael Alhaddad - The Red Sea Development Company
Mr Aber Alvi - The Red Sea Development Company
Mr Abdelfattah Saleh - The Red Sea Development Company
Mr Ahmed Nagy - The Red Sea Development Company
Mr Ahmed Rashed - The Red Sea Development Company
Mr Rodel Sanchez - The Red Sea Development Company

Sent Sunday, 12 January 2026

MESSAGE

Workflow Review History

The attached documents have completed the "Acoustic Spray Foam ACOUSTIEG" workflow with the following results:

This document was automatically generated

Doc No	Step	Participant	Review Outcome	Comments
R03-C05C01-BIC-MAT-AR-0054	QA/QC Check	M Sahwan	Accepted	
	TCC_AR	R Sanchez	Accepted	
	SU_Review	A Alvi	Review Not Required	Provide VOC emissions test report from ISO 17025 accredited lab showing that the product has been tested as per (CDPH) Standard Method v1.2-

Seven -Jazan Out Door Factory (ODF)





MAIL TYPE Transmittal	MAIL NUMBER FNC-TRANSMIT-001748	REFERENCE NUMBER DAE-WTRAN-044818
--------------------------	------------------------------------	--------------------------------------

Fwd: Final (WF-026618) 0003- Material Submission - Main Work Contractor-P6-Jazan Main Works-Material submittal for BoSpray Acoustic Spray for Ceiling from ACOUSTIEG (Outdoor Factory) Rev-1 Cat-0

From Mr Bahaa Salim - Alfanar Company for development and construction

To (5) Mr Joseph Mendoza - ACIKHAVA INT. CONTRACTING (OUTDOOR FACTORY) (+4 more...)

Cc Mr Hesham Mahmoud - Alfanar Company for development and construction

Sent Tuesday, 17 June 2025 12:19:29 PM AST (GMT +03:00)

Reason Issued for Information

Status N/A

DOCUMENT ATTACHMENTS (1)

(0 selected)						
File	Document No	Revision	Revision Date	Title	Status	Planned Submission Date
	6JAZN11-JAZN-08-FNC-AC-MAT-00002	1	03/06/2025	P6-Jazan Main Works-Material submittal for BoSpray Acoustic Spray for Ceiling from ACOUSTIEG (Outdoor Factory) Rev-1 Cat-0	B - Approved with Comments	

ATTRIBUTES

Attribute 1 AC - Acoustics, PM - Project Management

MESSAGE

ISO 9001:2015

Certificate of Registration



This is to certify that the Quality Management System of

ACOUSTIEG

QPR1+1PJ, Othman Bin Affan Road, Al Falah, Riyadh, 11314, KSA

is in accordance with the requirements of the following standard

ISO 9001:2015

(Quality Management System)

SCOPE

General Construction And Acoustic Testing Services

(IAF Code: 28,34)

Certificate Number : 11112-111-1

To verify certificate, visit at :

www.arscert.com

www.uafaccreditation.org

www.iafcertsearch.org

Initial Registration Date : 11-Nov-10

1st Surveillance Date : 11-Oct-10

2nd Surveillance Date : 11-Oct-11

Certificate Expiry Date : 10-Nov-11

Issued by ARS Assessment Private Limited



Managing Director







UAF Address : 100, North Center Dr, STE 101, Norfolk, VA 23501, United States of America

This certificate remains the property of ARS and must be returned to ARS on Cancellation or Suspension of the certificate. Validity of the certificate is subject to successful completion of surveillance audits. Further clarification regarding the scope of this certificate and the applicability of standard may be obtained by consulting the Organisation on info@arscert.com

ISO 14001:2015



Certificate of Registration

This is to certify that the Environmental Management System of

Establishment Al-Banna Walazel for Contracting "ACOUSTIEG"

KSA - Uthman Ibn Affan Rd, Al Falah, Riyadh 11314

is in accordance with the requirements of the following standard

ISO 14001:2015

(Environmental Management System)

SCOPE

Acoustic assessments, designs and installation of soundproofing and noise control solutions

(IAF Code: 28,34)



Certificate Number : 20114-01511

Initial Registration Date : 10-Dec-2014
^{1st} Surveillance Date : 10-Nov-2015
^{2nd} Surveillance Date : 10-Nov-2016
 Certificate Expiry Date : 10-Dec-2017

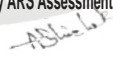

To verify certificate, visit at :

www.arscert.com
www.uafaccreditation.org
www.iafcertsearch.org

Issued by ARS Assessment Private Limited

Managing Director

UAF Address : 100, North Center Dr, STE 101, Norfolk, VA 23501, United States of America

This certificate remains the property of ARS and must be returned to ARS on Cancellation or Suspension of the certificate. Validity of the certificate is subject to successful completion of surveillance audits. Further clarification regarding the scope of this certificate and the applicability of standard may be obtained by consulting the Organisation on info@arscert.com

ACOUSTIEG®
ACOUSTIC EXPERIENCE ELEVATED

ACOUSTIEG COMPANY

For Business Inquiries Contact us:

+966 59 140 2722

www.acoustieg.com

Info@acoustieg.com

Riyadh, Saudi Arabia



Visit Our Website